

## ATTENTION TO DETAIL



1905 FURNITURE OF THE MINNESOTA STATE CAPITOL

ATTENTION TO DETAIL  
1905 FURNITURE OF THE MINNESOTA STATE CAPITOL

MINNESOTA HISTORICAL SOCIETY  
CAPITOL HISTORIC SITE  
ST. PAUL, MINNESOTA  
1989

On the cover: Mahogany settees between breche violette marble columns, 2nd Floor, West Wing, Minnesota State Capitol (see page 30). Photo by Erick Vryens. The corner design detail used on the cover and throughout this report are reminiscent of the corner design found in the corridors surrounding the Rotunda on the Ground and 1st floors of the Capitol.

Published by: The Minnesota Historical Society  
Nina Archabal, Director  
Donn Coddington, Assistant Director for Historic Sites and Field Programs  
Thomas Woods, Head, Historic Sites

Prepared by: Carolyn Kompelien, Capitol Historic Site Manager  
Kendra Dillard, Curator of Historic Sites Collections  
Sherri Gebert Fuller, Researcher/Writer

Illustrations: Cass Gilbert (all line drawings, except those listed below, from 1903 "Specifications for Cabinet Work, Furniture, and Furnishings" and rough sketches)

Scott Chase (line drawings on pages 16-20, 22, 23, 25, and 51)

Editing/design/  
production: Ellen B. Green

Printing: Sexton Printing, Inc.

© 1989 by Minnesota Historical Society. All rights reserved.

Manufactured in the United States of America.

The Minnesota State Capitol's original 1905 furniture has been a concern of the Minnesota Historical Society since the building was placed on the National Register of Historic Places and began operating as a State Historic Site in 1969. The furniture, designed by preeminent architect Cass Gilbert and constructed by prestigious New York firms, plays an integral role in the decorative scheme of the Capitol interior. Reorganization of the Capitol Historic Site Program in 1984, along with renewed interest in restoration of the Capitol, provided the impetus for the Society to begin an inventory of the original furniture.

Cass Gilbert included in his detailed plans for the Capitol both standard designs of furniture, available commercially at the turn of the century, and specialized furniture that he designed himself for public and ceremonial spaces throughout the building. The contract to build both the standard and specialized furniture was awarded to Herter Brothers of New York (and its subcontractors) and included seventy-four styles of chairs, tables, and desks.

By September 1989, approximately eight hundred pieces of 1905 furniture in fifty-four styles, or roughly one-half the original order, had been located in fifteen different state buildings. Although most of the pieces Gilbert designed have remained in the building, four of his approximately forty-two styles are yet to be found. They include two styles of desks assigned to the Governor's Suite of Offices and a writing desk and chair originally located in the House Retiring Room (see pages 53 and 54). Unfortunately, much of the original standard furniture from the Capitol was, over the years, discarded, auctioned off by the state, or relocated to other government agencies throughout Minnesota. Sixteen of the thirty-two styles of standard furniture are nonextant.

The Capitol Historic Site Program has been established as the information center for the Capitol's original furniture by completing an inventory and thoroughly documenting the surviving pieces. In accordance with Minnesota Historical Society Museum Collections

cataloging procedures, each piece has been marked with a unique number, measured, researched, and described in great detail. This work concurs with state statutes defining the Minnesota Historical Society's role in the placement and preservation of works of art, including furniture, in the Capitol.

The tedious process of locating early Capitol furniture has been facilitated by a number of sources available at the Minnesota Historical Society (see bibliography on page 55). These publications include photographs taken soon after the Capitol opened in 1905 of the building's newly completed interior and furnishings. The Historical Society's audiovisual library also has a fine collection of photographs documenting the many facets of the Capitol's interior and how it has changed over time. The photographs, evidence of how frequently the 1905 furniture has been moved, provide insight as to why so many pieces are no longer in their original settings.

This report will familiarize readers with existing 1905 furniture, its history, and current locations. Measurements are given in centimeters and may vary slightly among pieces of the same style. Pieces in permanent locations (such as rostrums and clerks' desks in the House and Senate Chambers and the judge's bench and gate in the Supreme Court) are not included here but were also designed by Gilbert and constructed by the Herter Brothers. Additional information about these pieces may be obtained by contacting the Capitol Historic Site office.

The Society's ultimate goal is to return appropriate 1905 furniture to public and ceremonial spaces within the Capitol. Such placement will enhance current restoration efforts and ensure the continued preservation of an integral part of the Minnesota State Capitol's important architectural history.

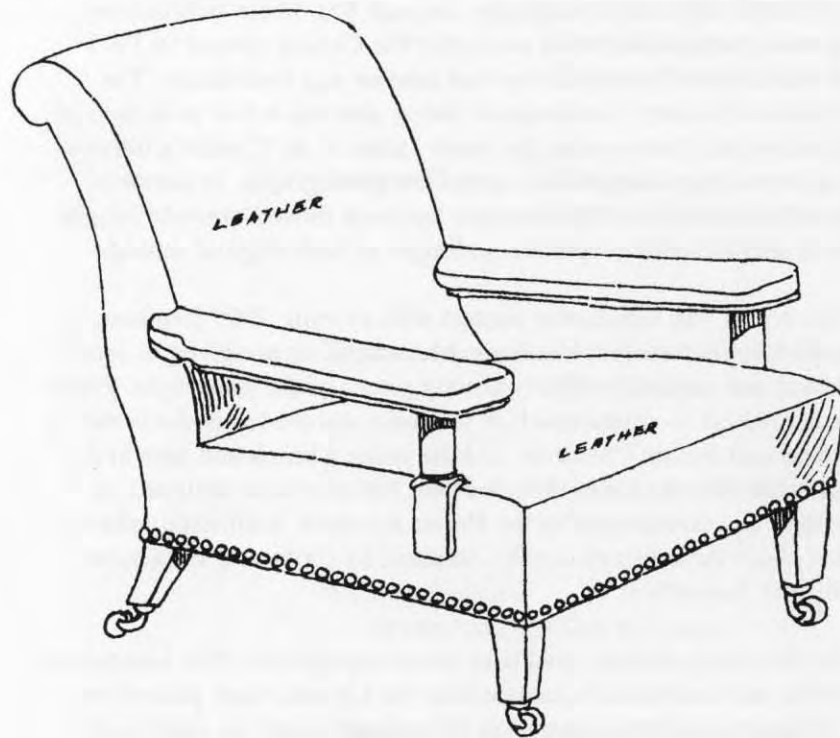

STYLE: AK EASY CHAIR

MAKER: Probably Marble & Shattuck Chair Company,  
Cleveland, Ohio

MEASUREMENT: 92h x 68w x 72d

DESCRIPTION: The brown leather-upholstered AK easy chair is oak or mahogany. It has a large, square backrest, leaning slightly away from the seat and outlined with 2-cm brass tacks on the reverse side. Flat wooden arms broaden slightly from back to front. Columnar, turned arm supports adjoin the large, square leather-upholstered seat and skirt, which is outlined with 2-cm brass tacks along the bottom. Plain, flat tapered legs end in castors. The rear legs flare out slightly.

HISTORY: Designed by Cass Gilbert for the Governor's Suite of Offices, the Attorney General's Library and the House of Representatives' Retiring Room

1905 ORDER: 24

1989 TOTAL : 13

LOCATION: Capitol, B59 (1)  
Capitol, Governor's Anteroom (3)  
Capitol, Governor's Formal Office (4)  
Capitol, House Lobby (3)  
Labor and Industry Building, 2nd Floor, Claims Settlement (2)

STYLE: AF ARMCHAIR

MAKER: Probably Marble & Shattuck Chair Company,  
Cleveland, Ohio

MEASUREMENT: 86h x 52w x 62d

DESCRIPTION: The AF mahogany open armchair has a capital-shaped splat framed between a wide, curved top rail and a narrow bottom rail. The rectangular stiles widen as they curve into the side seat rails. Inscribed open arms extend out from the stiles, curving down and around to the side seat rails. Below the brown leather-upholstered seat is a plain, recessed skirt. Plain, flat, tapered legs flare out slightly in front and rear.

HISTORY: Designed by Cass Gilbert for the Governor's Suite of Offices, the Senate Retiring Room, and the Supreme Court Chamber

1905 ORDER: 32 (plus 12 ordered circa 1906)

1989 TOTAL : 43

LOCATION: Capitol, 224 (1)  
Capitol, 317 (1)  
Capitol, Supreme Court, 2nd Floor Minor  
Corridors (7)  
Capitol, Governor's Anteroom (1)  
Capitol, Governor's Formal Office (5)  
Capitol, Governor's Private Office (5)  
Capitol, Governor's Reception Room (9)  
Capitol, Senate Retiring Room (8)  
Capitol, Supreme Court Chamber (6)

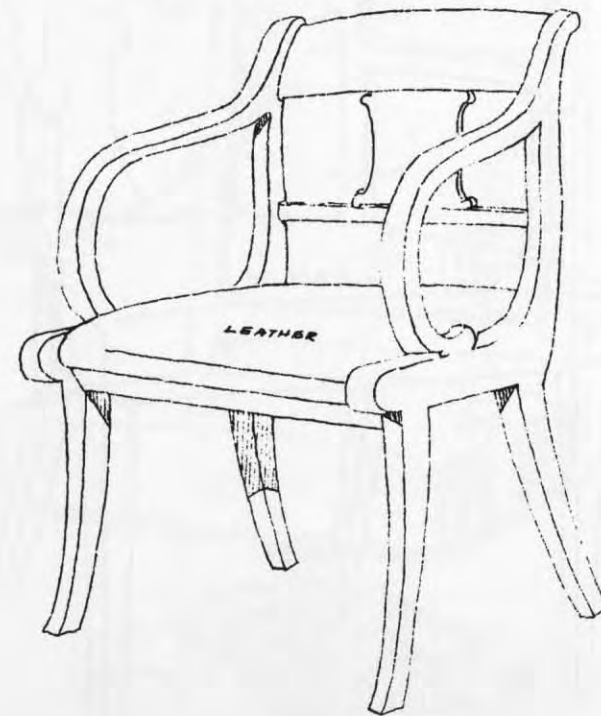

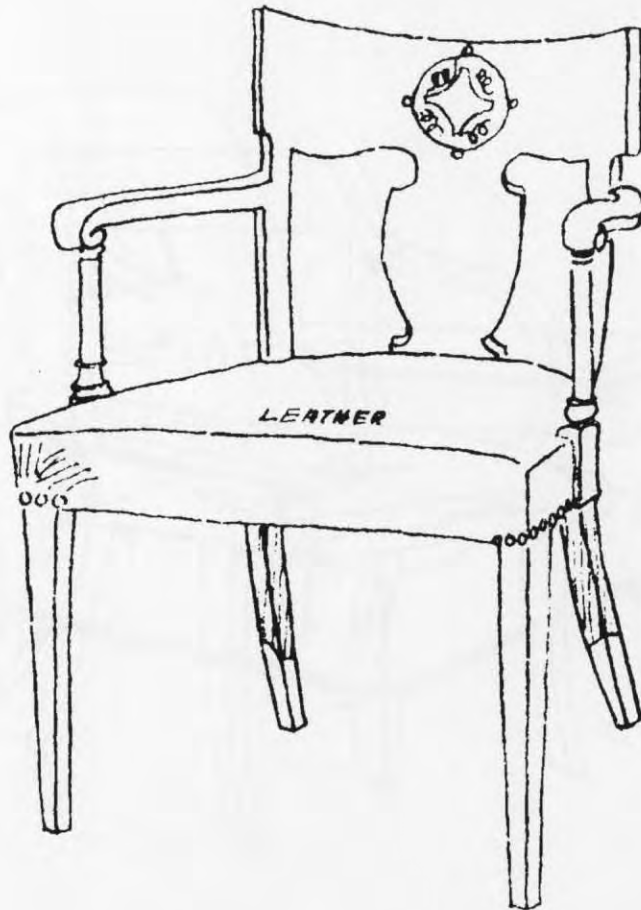

STYLE: AN ARMCHAIR

MAKER: Marble & Shattuck Chair Company, Cleveland, Ohio

MEASUREMENT: 94h x 58w x 50d

DESCRIPTION: The AN mahogany open armchair has a wide top rail curving in at the center and adjoining a pierced urn-shaped splat ornamented with a stylized carving of a lady slipper atop a shell.\* Rectangular stiles broaden and curve into the seat rail. The armrests extend out from the midpoint of the stiles and broaden slightly to scrolled handholds. Turned arm supports meet the straight-sided seat, which widens toward the front. Brown leather upholstery covers the seat rails, and 2-cm brass tacks outline the bottom of the skirt. Plain, flat, tapered legs flare out slightly in the rear.

HISTORY: Designed by Cass Gilbert for the Governor's Reception Room

1905 ORDER: 4

1989 TOTAL : 2

LOCATION: 525 Park Building, 2nd Floor, Attorney General (1)  
Capitol, B59 (1)

\* The AN chair design was altered from Cass Gilbert's circa 1903 drawing.

STYLE: CC CEREMONIAL CHAIR

MAKER: Herter Brothers, New York, New York

MEASUREMENT: 142h x 65w x 62d

DESCRIPTION: The CC mahogany revolving open armchair has a wide top rail with a carved cresting of the North Star motif framed in oak leaves. A star emblem is in the center of the carved open scroll, which reads "L'etoile [du] Nord." Narrow, plain, flat stiles extend up from the seat to form a rectangular backrest. The straight, bottom rail encloses a brown leather-upholstered back panel. The armrests are decorated with foliage carving near the stiles and end in scrolled handholds. Turned arm supports meet the plain leather seat. Leather extends over the skirt, which is outlined with 2-cm brass tacks. A central metal support under the seat fits into a base joining four slanting wooden legs with claw feet ending in castors.

HISTORY: Designed by Cass Gilbert for the Senate and House Chambers

1905 ORDER: 2

1989 TOTAL : 2

LOCATION: Capitol, House Retiring Room (1)  
Capitol, Senate Chamber (1)

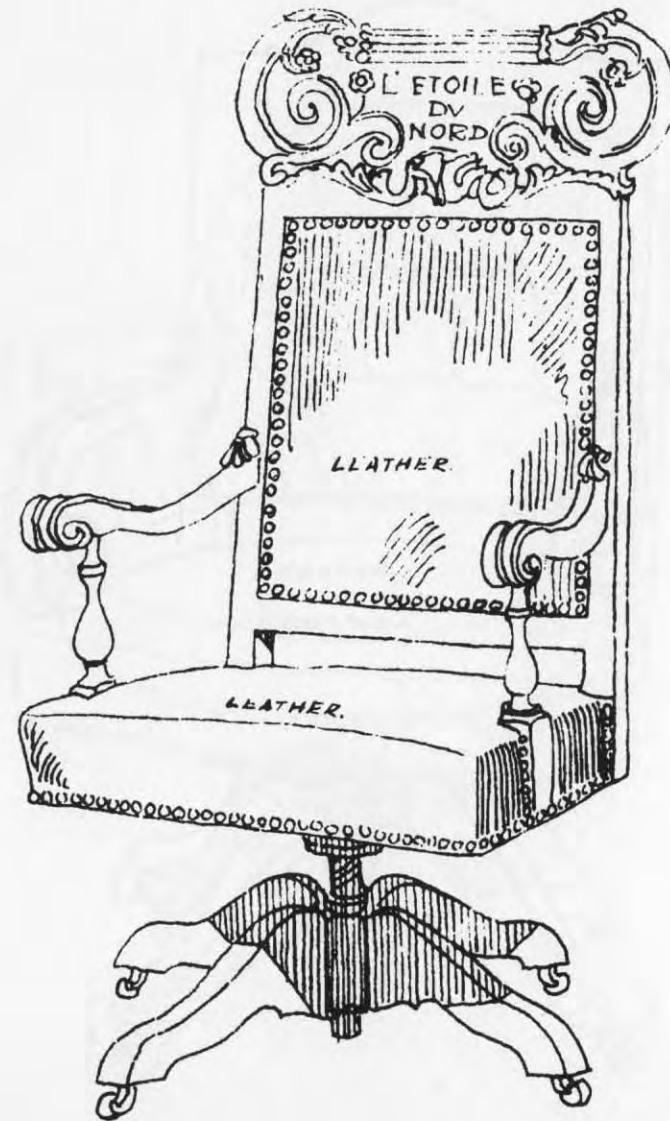



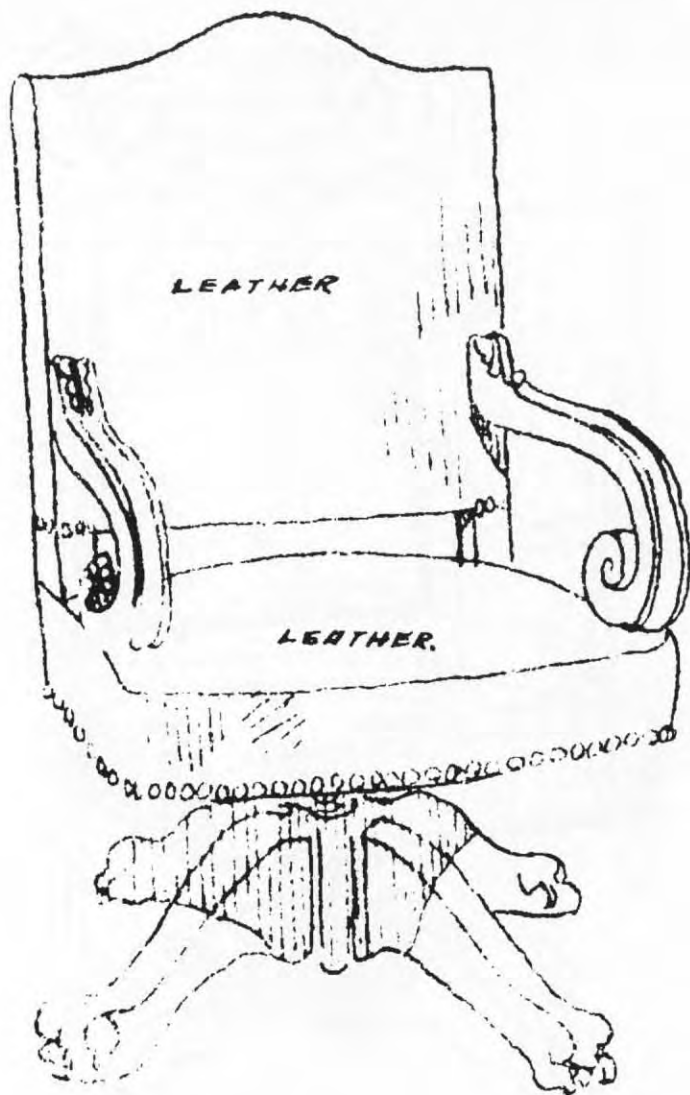

STYLE: DD SWIVEL CHAIR

MAKER: Marble & Shattuck Chair Company, Cleveland, Ohio

MEASUREMENT: 96h x 62w x 50d

DESCRIPTION: The DD mahogany revolving open armchair with arched top rail has a leather-upholstered rectangular backrest, which was originally outlined with 1-cm brass tacks on the reverse side. Wooden stiles emerge from the bottom of the upholstered backrest to connect with the seat. Armrests curve out from the backrest in a continuous loop, ending in a scroll with a carved rosette in the center. Carved foliage decorates the junction of the armrest and backrest. The plain seat and skirt are brown leather-upholstered, and the bottom of the skirt is outlined with 2-cm brass tacks. A central metal support under the seat fits into a base joining four slanting wooden legs with claw feet, ending in castors.

HISTORY: Designed by Cass Gilbert for the Senate and House Chambers and the Supreme Court Consultation Room

1905 ORDER: 191

1989 TOTAL : 80

LOCATION: Capitol, Senate Chamber and Retiring Room (79)  
Governor's Private Office (1)

STYLE: EE SWIVEL CHAIR

MAKER: Marble & Shattuck Chair Company, Cleveland, Ohio

MEASUREMENT: 94h x 62w x 59d

DESCRIPTION: The EE mahogany revolving open armchair has an oval, tufted, brown leather backrest connected by exposed curved, plain, flat stiles to the seat. S-curved armrests extend from the backrest and end in scrolled handholds. Arm supports curve in to a circular leather-upholstered seat and skirt, which is outlined with 2-cm brass tacks at the bottom. A central metal support under the seat fits into a base joining four slanting wooden legs on castors.

HISTORY: Designed by Cass Gilbert for clerks and reporters in the Senate and House Chambers.

1905 ORDER: 30

1989 TOTAL : 12

LOCATION: Capitol, West Senate Gallery Attic (12)

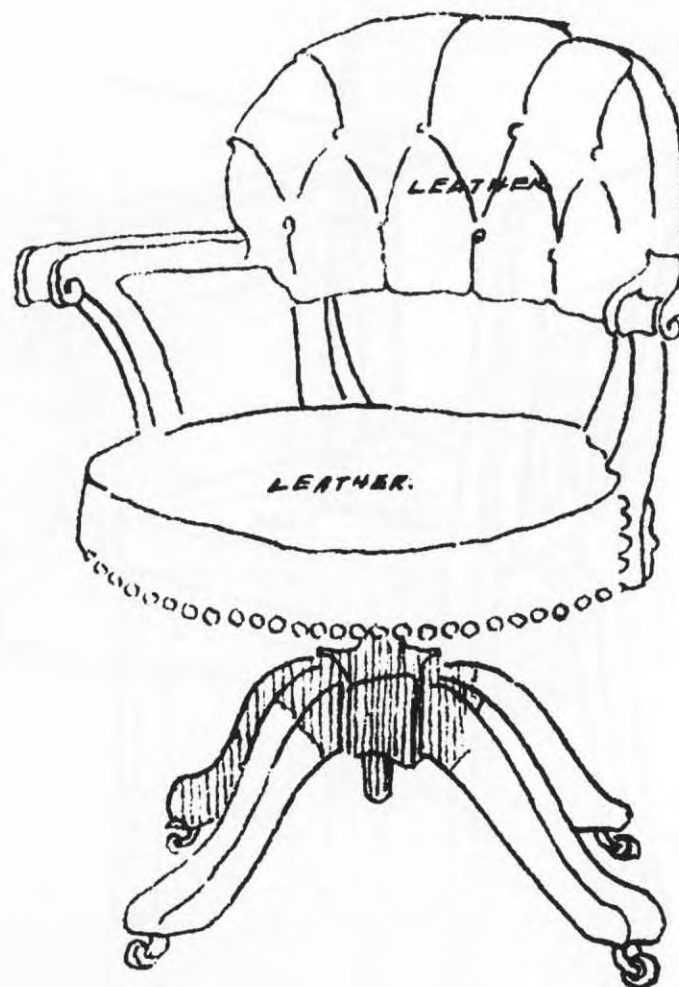

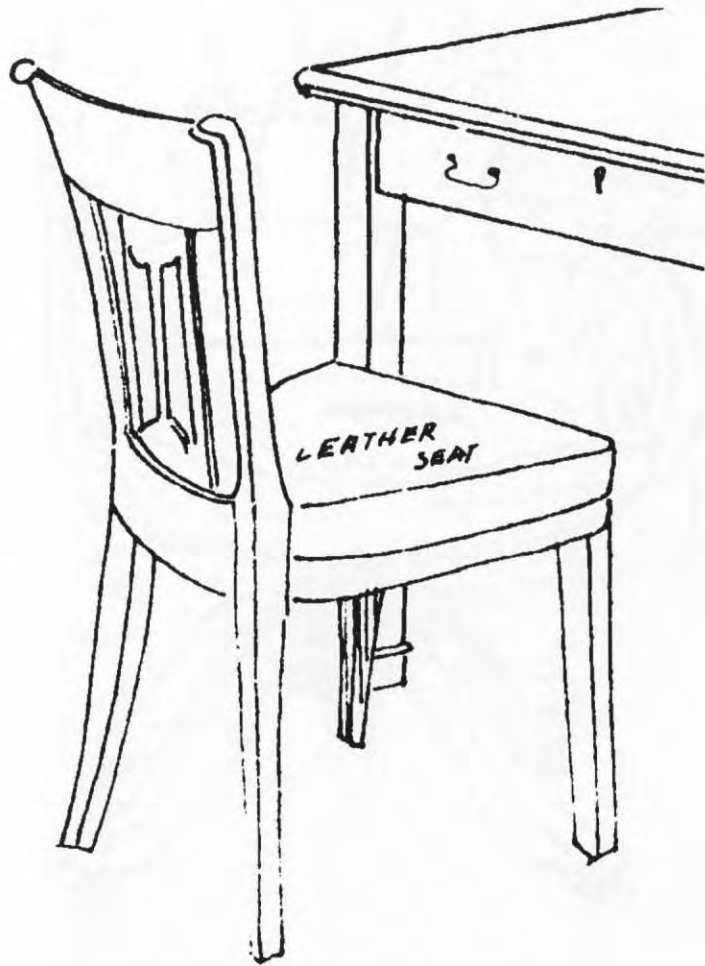

STYLE: JJ SIDE CHAIR

MAKER: Probably Marble & Shattuck Chair Company,  
Cleveland, Ohio

MEASUREMENT: 93h x 52.5w x 48.5d

DESCRIPTION: The JJ mahogany side chair has a wide top rail and a pierced splat with a fanlike floral motif scored with fine ridges directly below the center of the top rail. The splat fits into a shoe in the rear seat rail. Plain, tapered stiles flare out slightly from a straight-sided seat that widens to the front. Brown leather covers the seat rails. Originally, 2-cm brass tacks outlined the bottom of the upholstered skirt. The plain, flat tapered legs are extensions of the stiles.

HISTORY: Designed by Cass Gilbert for the Senate Retiring Room (mahogany) and the House Retiring Room (oak)

1905 ORDER: 3  
1989 TOTAL : 1

LOCATION: State Office Building, 622 (1)

STYLE: FF CEREMONIAL CHAIR

MAKER: Herter Brothers, New York, New York

MEASUREMENT: 135h x 66w x 61d

DESCRIPTION: The FF mahogany revolving open armchair has a scrolled top rail\* with carved foliage ornamentation, a bottom rail, and plain flat stiles extending up from the brown leather-upholstered seat to form a rectangular backrest. An upholstered leather cushion is fitted into the stiles and outlined with 1-cm tacks. Wooden arms curve out from the stiles to scrolled handholds and are partially upholstered. The carved arm supports curve in to meet the seat. The upholstery extends over seat rails, and the bottom of the skirt is outlined with 2-cm brass tacks. A central metal support under the seat fits into a base joining four slanting wooden legs with claw feet on castors.

HISTORY: Designed by Cass Gilbert for the Supreme Court Chamber

1905 ORDER: 5 (plus 2 reproductions circa 1929 and 2 reproductions circa 1974)

1989 TOTAL : 9

LOCATION: Capitol, B59 (2)  
Capitol, Supreme Court Chamber (7)

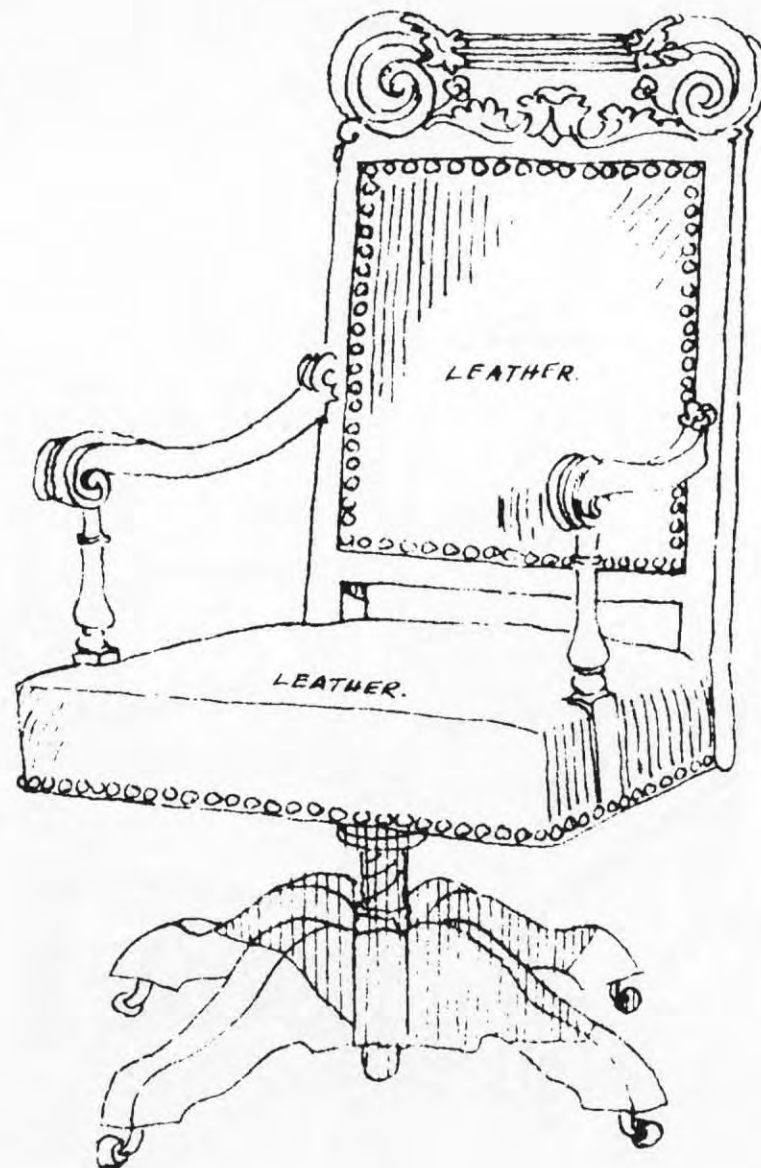

\* The midsection of the top rail on the Chief Justice chair is ornamented with a palmette carving.

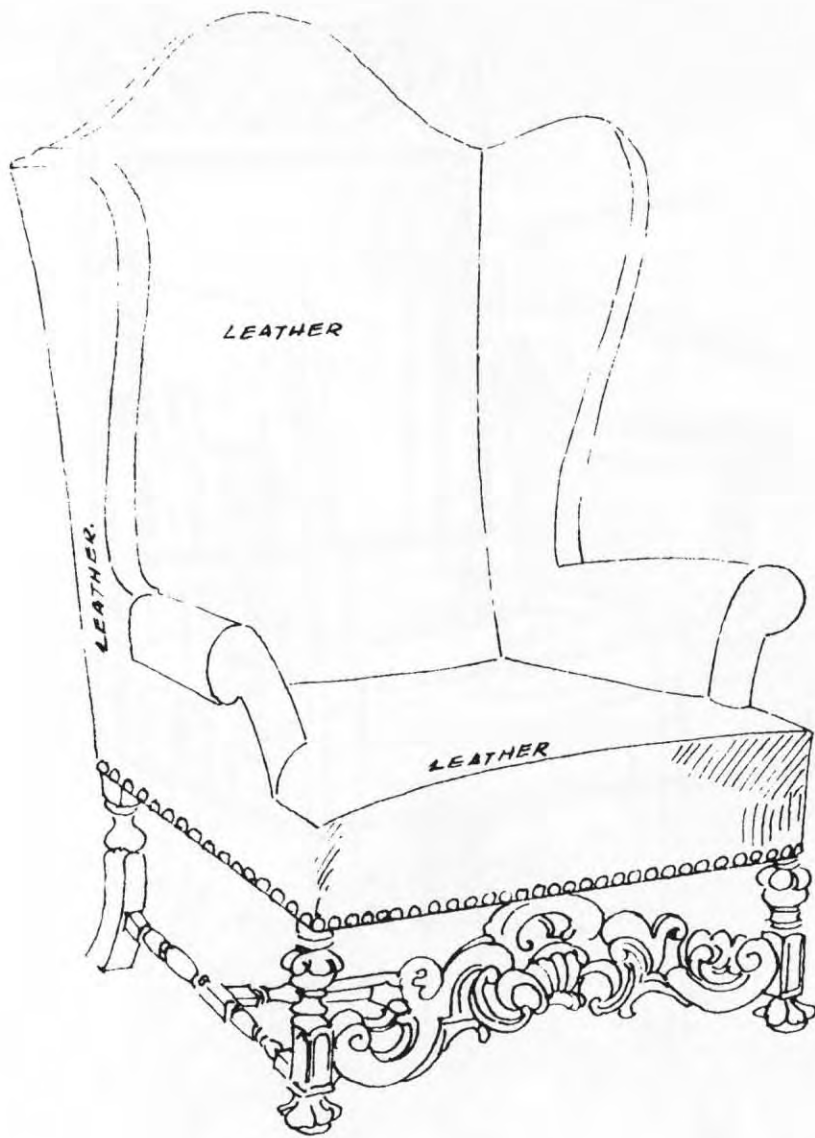

STYLE: PP EASY CHAIR

MAKER: Marble & Shattuck Chair Company, Cleveland, Ohio

MEASUREMENT: 140h x 72w x 64d

DESCRIPTION: The PP brown leather-upholstered Queen Anne easy chair has wings at right angles to the back and a rounded top rail. The exterior edge of each wing and the reverse side of the chair are outlined with 2-cm brass tacks. Horizontal rolls serve as armrests, and the exteriors of the arm supports are outlined with 2-cm brass tacks. The plain seat and skirt are upholstered in leather, and the bottom of the skirt is outlined with 2-cm brass nails. Turned side stretchers meet a central turned stretcher. A detailed floral-scroll-leaf-carved stretcher adjoins the two front legs, which are turned and end in inscribed bun feet. The tops of the rear legs are turned and flare out slightly to plain bottoms.

HISTORY: Designed by Cass Gilbert for the Senate Retiring Room

1905 ORDER: 4

1989 TOTAL : 4

LOCATION: Capitol, Senate Retiring Room (4)

STYLE: NN EASY CHAIR

MAKER: Marble & Shattuck Chair Company, Cleveland,  
Ohio

MEASUREMENT: 100h x 96w x 80d

DESCRIPTION: The NN brown leather-upholstered easy chair has a pleated top rail and a diamond-tufted backrest with leather-covered buttons. The reverse side of the chair is outlined with 2-cm brass tacks. Pleated horizontal rolls serving as armrests adjoin the plain seat and skirt. Two-cm brass tacks outline the skirt bottom and the exteriors of the arm supports. The plain, flat, tapered wooden legs end in castors and flare out slightly in the rear.

HISTORY: Designed by Cass Gilbert for the Governor's Reception Room, the Lieutenant Governor's Office, the Senate Retiring Room, and the House Chamber

1905 ORDER: 19  
1989 TOTAL : 7

LOCATION: Capitol, Governor's Reception Room (4)  
Capitol, Senate Retiring Room (2)  
State Office Building, House Research,  
6th Floor (1)

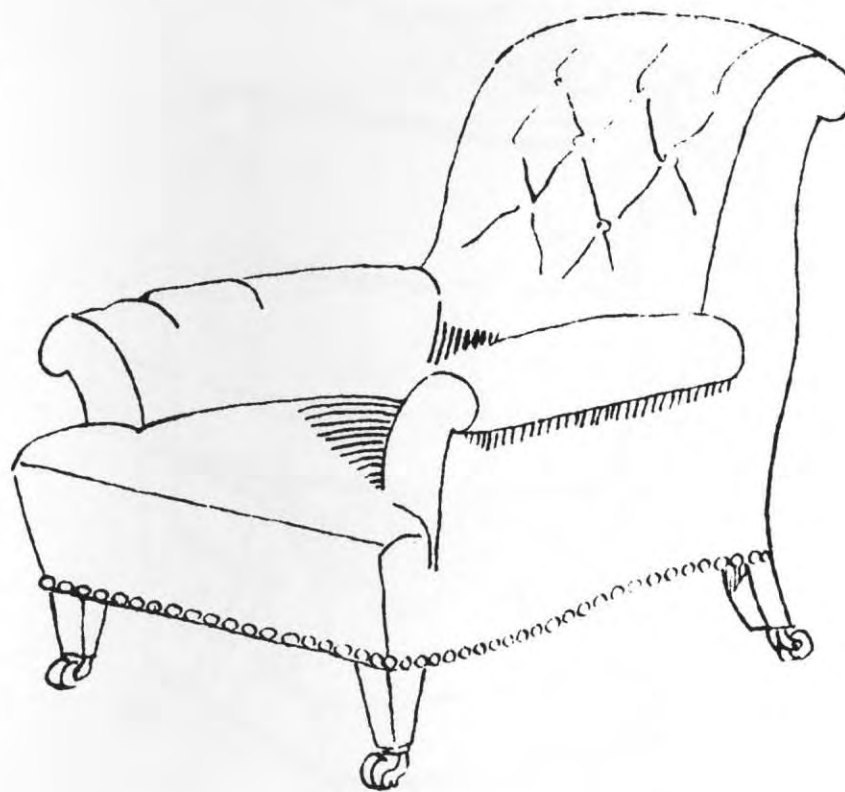

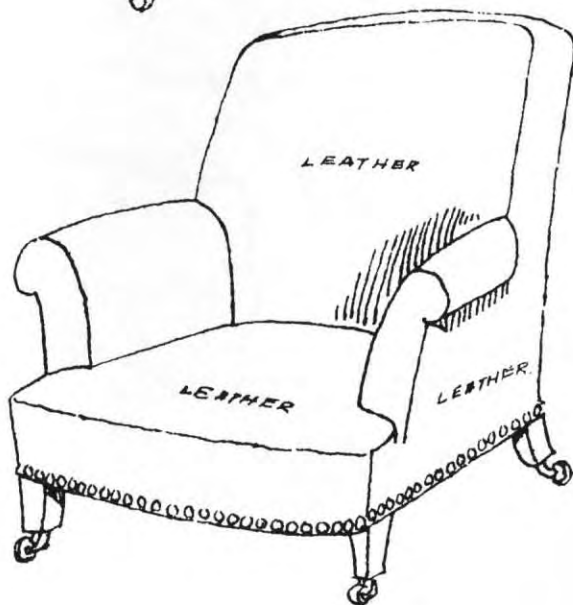
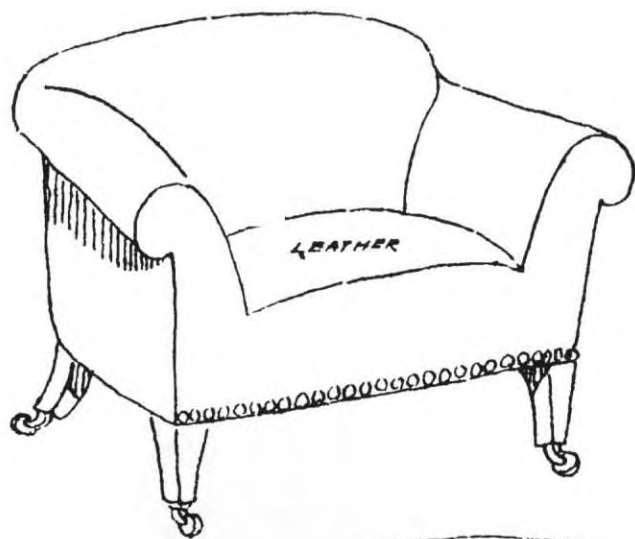

STYLE: WW EASY CHAIR

MAKER: Marble & Shattuck Chair Company, Cleveland, Ohio

MEASUREMENT: 83h x 76w x 66d  
97h x 80w x 72d

DESCRIPTION: The WW brown leather-upholstered easy chair has a square or rectangular backrest with a rounded top rail. The backrest is outlined with 2-cm brass tacks on the reverse side. Horizontal leathered rolls serving as armrests adjoin the plain seat and skirt. Two-cm brass tacks outline the bottom of the skirt and extend up along the exterior of the arm supports. Plain, flat tapered legs end in castors, and rear legs flare out slightly.

HISTORY: Designed by Cass Gilbert for minor corridors adjacent to House Chamber

1905 ORDER: 8 (plus 3 ordered circa 1906)

1989 TOTAL : 11

LOCATION: Capitol, B59 (1)  
Capitol, Governor's Anteroom (2)  
Capitol, Senate Retiring Room (4)  
State Office Building, 330 (2)  
State Office Building, 615 (1)  
State Office Building, House Research,  
6th Floor (1)

STYLE: TT SWIVEL CHAIR

MAKER: Herter Brothers, New York, New York

MEASUREMENT: 102h x 66w x 60d

DESCRIPTION: The TT brown leather-upholstered, revolving open armchair is outlined with 2-cm brass tacks along a yoke-shaped top rail and the sides of a rectangular back.\* Rosewood armrests curve out from the center of the plain, flat, exposed stiles near the seat, revealing carved feathers along the sides and widening to distinctive eagle-head handholds. Turned arm supports meet the leather seat, which widens to the front, and an upholstered skirt, outlined with 2-cm brass tacks along the bottom. A central metal support under the seat fits into the base, joining four slanting legs with claw feet ending in castors.

HISTORY: Designed by Cass Gilbert for the Governor's Suite of Offices and the Lieutenant Governor's Office

1905 ORDER: 7 (plus one ordered circa 1906)

1989 TOTAL : 8

LOCATION: 9 East Aurora, Plant Management, 202 (1)  
9 East Aurora, Plant Management, 210 (1)  
Capitol, 121 (1)  
Capitol, Governor's Reception Room (2)  
Capitol, Governor's Formal Office (1)  
Capitol, Governor's Private Office (1)  
Ford Building, 2nd Floor, Attorney General (1)

\* The TT chair design was altered from Cass Gilbert's circa 1903 drawing.

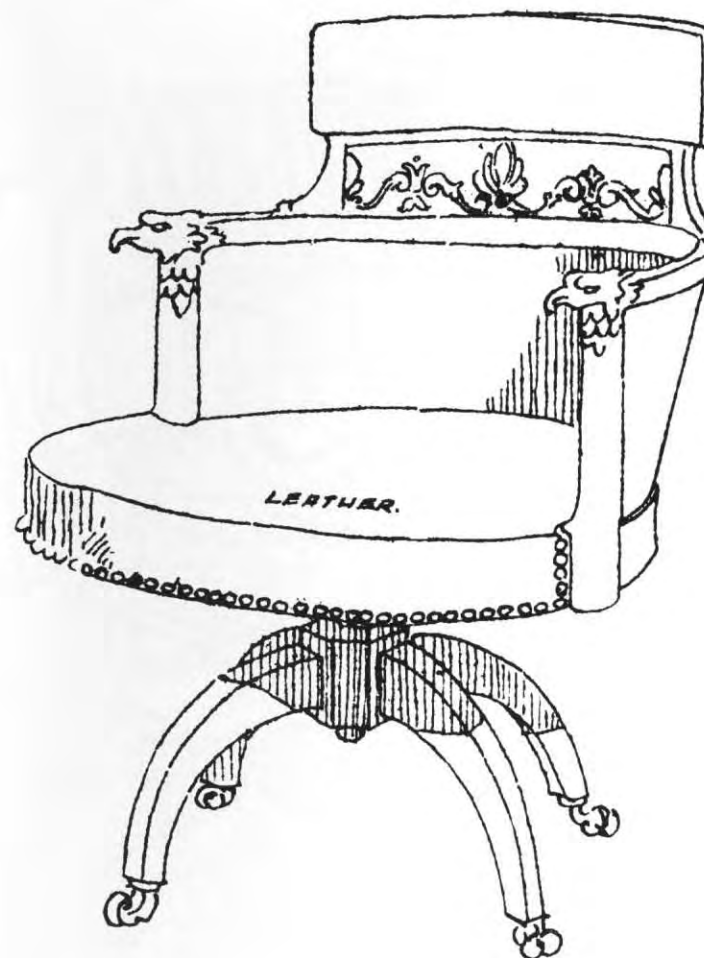





STYLE: 473 ARMCHAIR

MAKER: Marble & Shattuck Chair Company, Cleveland, Ohio

MEASUREMENT: 90h x 51w x 46d

DESCRIPTION: The 473 oak chair has a wide rectangular top rail, curving in at the center, with a rounded upper edge. A second, smaller rectangular rail joins the midpoint of tapered stiles. The arms curve down from the tops of the stiles in a continuous loop, ending in a scroll at the side of the seat rail, where a drop finial joins the arms to the square, brown leather seat. The leather upholstery, covering the narrow seat rails, is supported by webbing only. The front legs are turned, while the plain, tapered rear legs flare out slightly. The front stretcher is turned and bulbous, while the back and double side stretchers are plain.

HISTORY: Purchased by Cass Gilbert for Law Library and Historical Society Reading Rooms in the Capitol

1905 ORDER: 59

1989 TOTAL : 19

LOCATION: 525 Park Building, 2nd Floor, Attorney General (1)  
 American Center Building, 7th Floor, Public Service (3)  
 Capitol, B40 (1) Capitol, B59 (1)  
 Capitol, B60 (1)  
 Fort Snelling, Site Manager's Office (1)  
 James J. Hill House, 2nd Floor Office (4)  
 Minnesota Historical Society, 690 Cedar Street, 2nd Floor, Publications (2)

*(continued on next page)*

(continued)

Minnesota Historical Society, 690 Cedar Street,  
Audiovisual Library (3)  
State Office Building, 174 (2)

STYLE: 773 1/2 SWIVEL CHAIR

MAKER: Marble & Shattuck Chair Company, Cleveland,  
Ohio

MEASUREMENT: 81h x 58w x 51d

DESCRIPTION: The 773 1/2 oak, swivel open armchair has a wide top rail that slopes down and out, continuing into armrests and ending in plain handholds. Eight flat wooden rods extending from the top rail to the seat form a backrest. Arm supports curve in to meet a plain wooden seat with a narrow skirt and brown leather-upholstered inset cushion. A central metal support under the seat fits into a base joining four slanting wooden legs on castors.

HISTORY: Purchased by Cass Gilbert for offices throughout the  
Capitol

1905 ORDER: 21

1989 TOTAL : 2

LOCATION: Capitol, B60 (1)  
Fort Snelling, Minnesota Historical Society  
Archaeology Department (1)

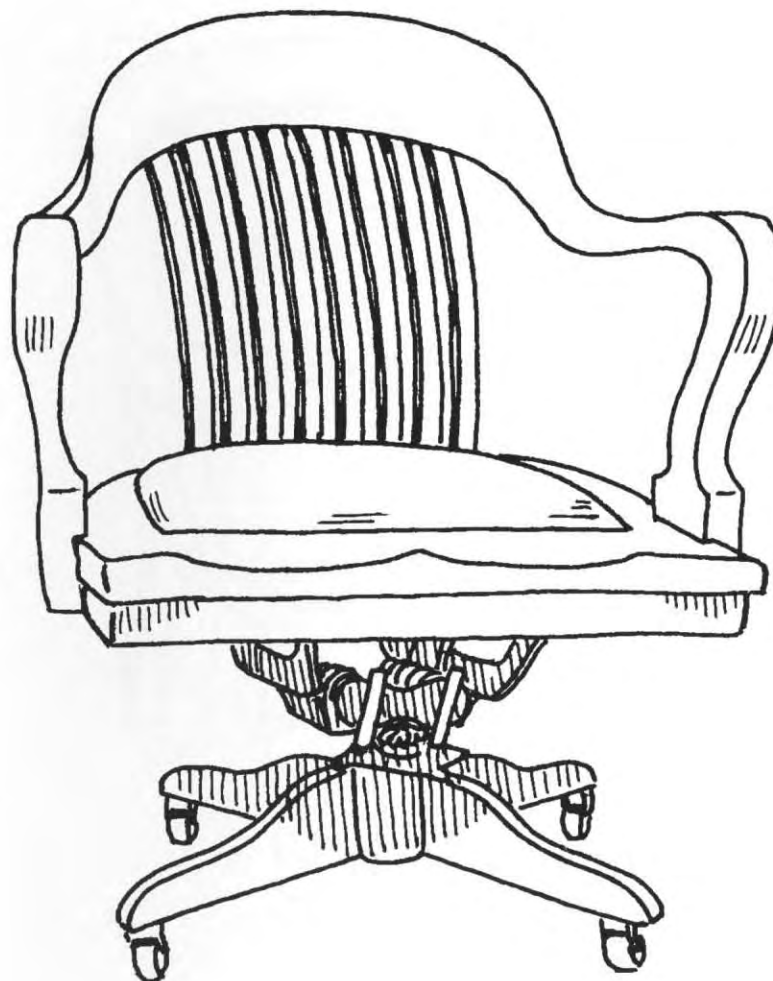

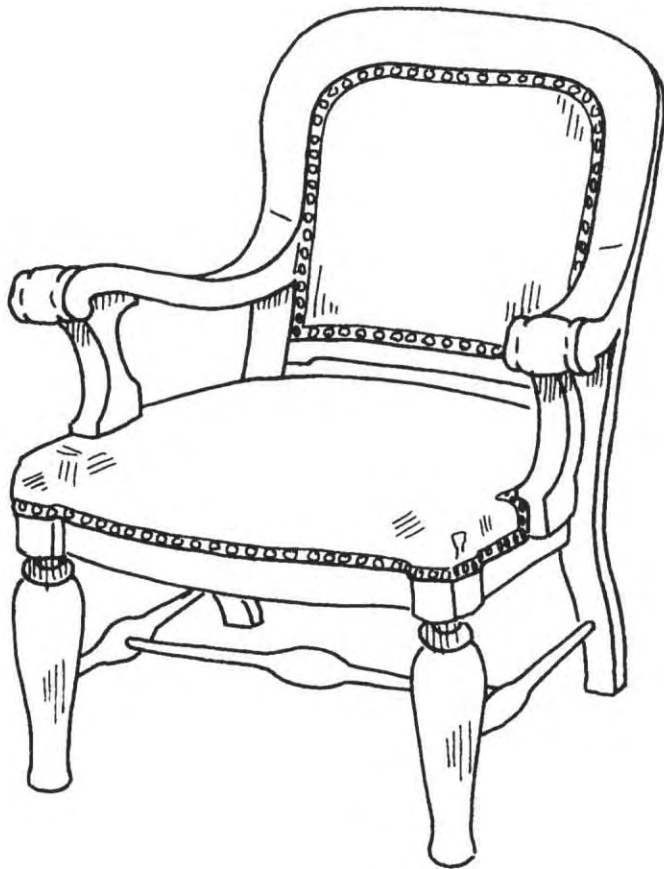

STYLE: 573 ARMCHAIR

MAKER: Marble & Shattuck Chair Company, Cleveland, Ohio

MEASUREMENT: 90h x 58w x 46d

DESCRIPTION: The 573 oak or mahogany open armchair with wide top rail and continuous stiles has a brown leather cushion fitted into the stiles and narrow bottom rail. The front and reverse sides of the square leather backrest are outlined with 1-cm upholstery tacks. The armrests slope down and out from the midpoint of the stiles and end in large scroll handholds. Arm supports curve into the upholstered seat. Leather covering the upper part of the skirt is outlined with 1-cm upholstery nails. Turned front legs end in small castors. Plain, tapered rear legs flare out slightly and are reinforced with bulbous H-pattern stretchers.

HISTORY: Purchased by Cass Gilbert for offices in the Capitol

1905 ORDER: 173

1989 TOTAL : 87

LOCATION: 9 East Aurora, Plant Management, 203 (1)  
American Center Building, 7th Floor,  
Public Utilities (14)

Capitol, B15 (2) Capitol, B59 (1)

Capitol, B55C, ZY Room (4) Capitol, B60 (7)

Capitol, G17 (1) Capitol, 101 (4)

Capitol, 102G (2) Capitol, 121 (6)

Capitol, 315 (1)

Capitol, Governor's Formal Office (2)

*(continued on next page)*

(continued)

Hastings Veterans Home, Storage (1)  
525 Park Building, 5th Floor, Attorney General (4)  
State Office Building, 13 (1)  
State Office Building, 132B (2)  
State Office Building, 132D (1)  
State Office Building, 145 (2)  
State Office Building, 148 (19)  
State Office Building, 267 (1)  
State Office Building, 463 (1)  
State Office Building, 467 (2)  
State Office Building, 635 (1)  
State Office Building, 705 (1)  
State Office Building, G13 (1)  
Transportation Building, 308 (1)  
Transportation Building, B20 (4)

STYLE: 1737 STOOL

MAKER: Marble & Shattuck Chair Company, Cleveland,  
Ohio

MEASUREMENT: 76h x 36w (seat)

DESCRIPTION: The 1737 oak stool has a round, plain, concave  
seat. Twelve bulbous stretchers of different lengths  
connect four tapered legs that are turned at the tops.

HISTORY: Purchased for offices throughout the Capitol

1905 ORDER: 21

1989 TOTAL : 2

LOCATION: Capitol, B4 (1)  
Capitol, B59 (1)

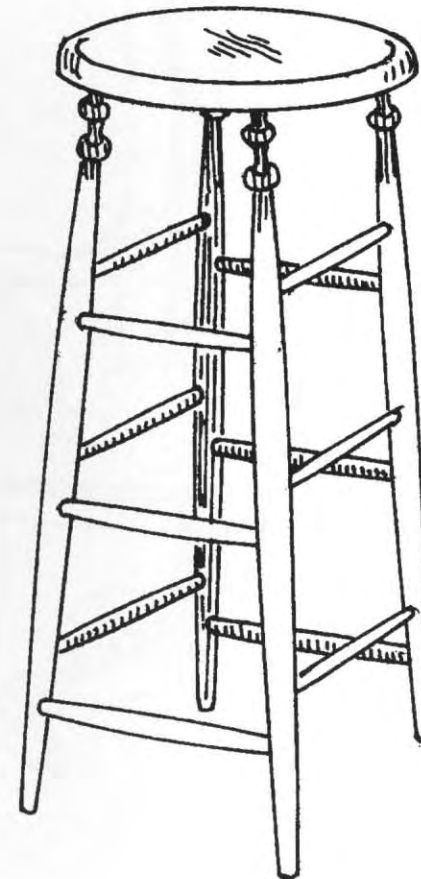

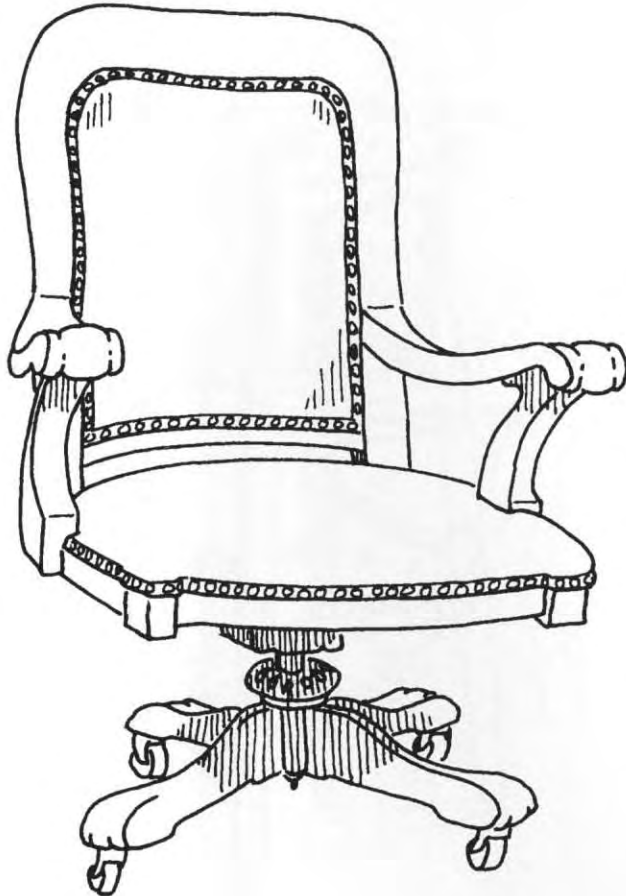

STYLE: 583 1/2 SWIVEL CHAIR

MAKER: Marble & Shattuck Chair Company, Cleveland, Ohio

MEASUREMENT: 106h x 67w x 70d

DESCRIPTION: The 583 1/2 oak or mahogany swivel open armchair with wide top rail and continuous stiles has a brown leather backrest fitted into the stiles and narrow bottom rail. The front and reverse sides of the rectangular backrest are outlined with 1-cm upholstery tacks. The armrests slope down and out from the midpoint of the stiles and end in large scroll handholds. Arm supports curve in to meet the upholstered seat. Leather covering the upper portion of the skirt is outlined with small upholstery tacks. A central metal support under the seat fits into a base joining four slanting legs with paw feet on castors.

HISTORY: Purchased by Cass Gilbert for offices throughout the Capitol

1905 ORDER: 77  
1989 TOTAL : 25

LOCATION: 9 East Aurora, Plant Management, 112 (1)  
9 East Aurora, Plant Management, 15 (1)  
9 East Aurora, Plant Management, 17 (1)  
9 East Aurora, Plant Management, 6 (1)  
9 East Aurora, Plant Management,  
Carpenters Shop (1)  
American Center Building, 7th Floor,  
Public Service (1)  
Capitol, B34 (1)

*(continued on next page)*

(continued)

Capitol, B44 (1)          Capitol, B60 (1)  
State Office Building, Basement Storage (1)  
State Office Building, G13 (1)  
State Office Building, G40 (1)  
State Office Building, G40A (1)  
State Office Building, 109 (1)  
State Office Building, 121 (1)  
State Office Building, 132B (1)  
State Office Building, 132D (1)  
State Office Building, 148 (5)  
State Office Building, 635 (1)  
State Office Building, 705 (1)  
State Office Building, 763 (1)

STYLE:            XX SIDE CHAIR

MAKER:           Probably Marble & Shattuck Chair Company,  
Cleveland, Ohio

MEASUREMENT: 93h x 52w x 45d

DESCRIPTION:   The XX oak side chair has a vase-shaped splat  
between a wide curved top rail and a back seat  
rail shoe. Columnar stiles widen as they join the  
back seat rail. The brown leather-upholstered  
seat is straight-sided and narrows at the rear.  
The rectangular, tapered legs flare out.

HISTORY:        Designed by Cass Gilbert for minor corridors  
adjacent to House Chamber

1905 ORDER:    8  
1989 TOTAL :    2

LOCATION:        State Office Building, 763 (2)

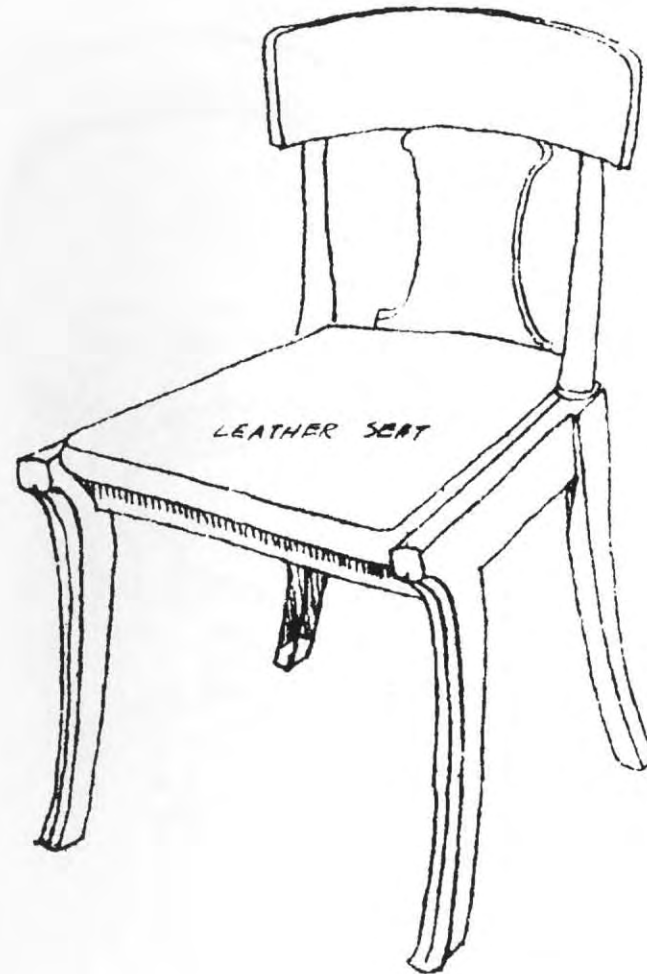

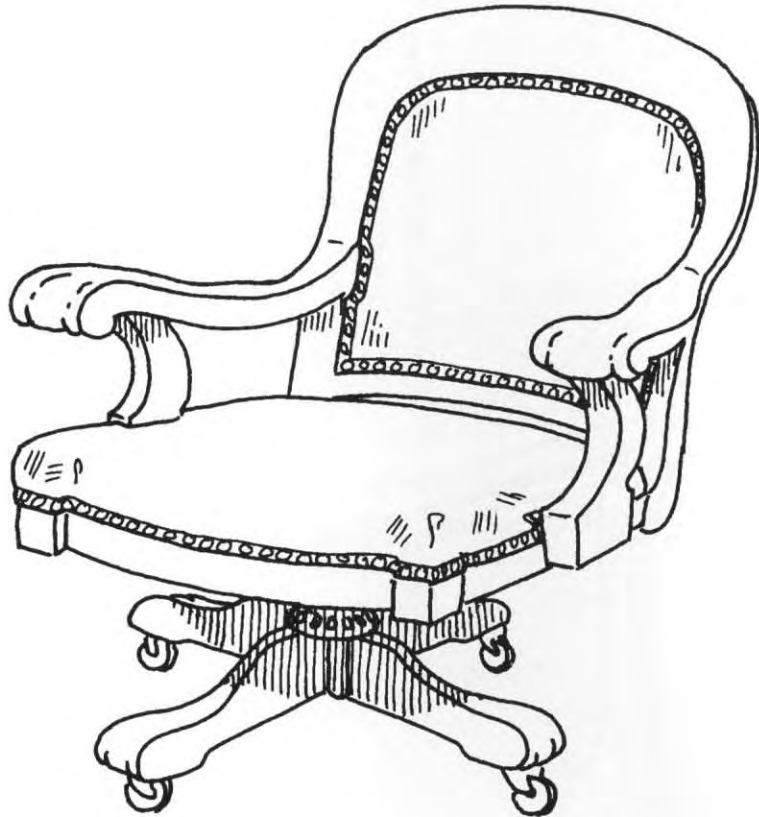

STYLE: 573 1/2 SWIVEL CHAIR

MAKER: Marble & Shattuck Chair Company, Cleveland, Ohio

MEASUREMENT: 91h x 60w x 46d

DESCRIPTION: The 573 1/2 oak or mahogany swivel open armchair with wide top rail and continuous stiles has a brown leather backrest fitted into the stiles and a narrow bottom rail. The front and reverse sides of the square leather backrest are outlined with 1-cm upholstery tacks. Armrests slope down and out from the midpoint of the stiles and end in large scroll handholds. Arm supports curve in to meet the upholstered seat. Leather covering the upper portion of the skirt is outlined with 1-cm upholstery tacks. A central metal support under the seat fits into a base joining four slanting wooden legs with paw feet on castors.

HISTORY: Purchased by Cass Gilbert for offices throughout the Capitol

1905 ORDER: 38

1989 TOTAL : 10

LOCATION: 9 East Aurora, Plant Management, 112 (1)  
 9 East Aurora, Plant Management, 113 (2)  
 Capitol, B60 (2)  
 Capitol, 104C (1)  
 State Office Building, 135 (1)  
 State Office Building, 148 (2)  
 State Office Building, near Room 143 (1)

STYLE: 1087 ARMCHAIR

MAKER: Marble & Shattuck Chair Company, Cleveland,  
Ohio

MEASUREMENT: 97h x 53w x 46d

DESCRIPTION: The 1087 oak open armchair has a yoke-shaped top rail turned up at the ends and a vase-shaped splat set into a shoe on the rear seat rail. S-curved armrests extend out from the midpoint of the tapered stiles and end in paw handholds. S-curved arm supports meet a straight-sided brown leather-upholstered seat that widens in front. Cabriole legs are at the front of the chair, and the rear tapered legs flare out. Plain, flat side stretchers meet a center support stretcher.

HISTORY: Purchased by Cass Gilbert for offices throughout the Capitol

1905 ORDER: 75

1989 TOTAL : 18

LOCATION: Capitol, B55C, ZY Room (4)  
Capitol, B59 (2)  
Capitol, B60 (1)  
State Office Building, G11 (1)  
State Office Building, G13 (1)  
State Office Building, G25 (2)  
State Office Building, 147 (6)  
Veterans Building, 131 (1)

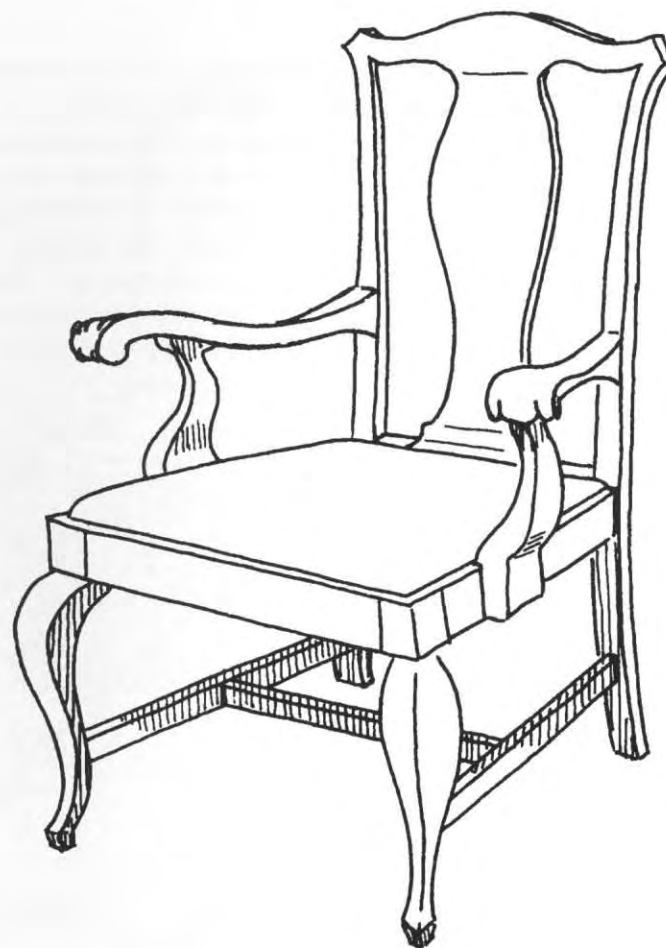



STYLE: MM SOFA

MAKER: Marble & Shattuck Chair Company, Cleveland, Ohio

MEASUREMENT: 92h x 212w x 74d

DESCRIPTION: The MM leather-upholstered sofa has a straight, pleated top rail and a diamond-tufted backrest with leather-covered buttons. The reverse side of the backrest is outlined with 2-cm brass tacks. The leather-upholstered armrests are pleated along the top and curve slightly outward. The sofa has a plain, attached leather and upholstered skirt. Two-cm brass tacks outline the front and sides of the seat rail and the exterior of each arm support. The plain, flat, wooden tapered legs end in castors.

HISTORY: Designed by Cass Gilbert for the Senate Retiring Room, Supreme Court Consultation Room, House Retiring Room and the Governor's Suite of Offices

1905 ORDER: 16

1989 TOTAL : 9

LOCATION: Capitol, 101 (1)  
Capitol, 102D (1)  
Capitol, 122 (1)  
Capitol, 205 (1)  
Capitol, Governor's Reception Room (1)  
Capitol, Governor's Formal Office (1)  
Capitol, Senate Retiring Room (3)

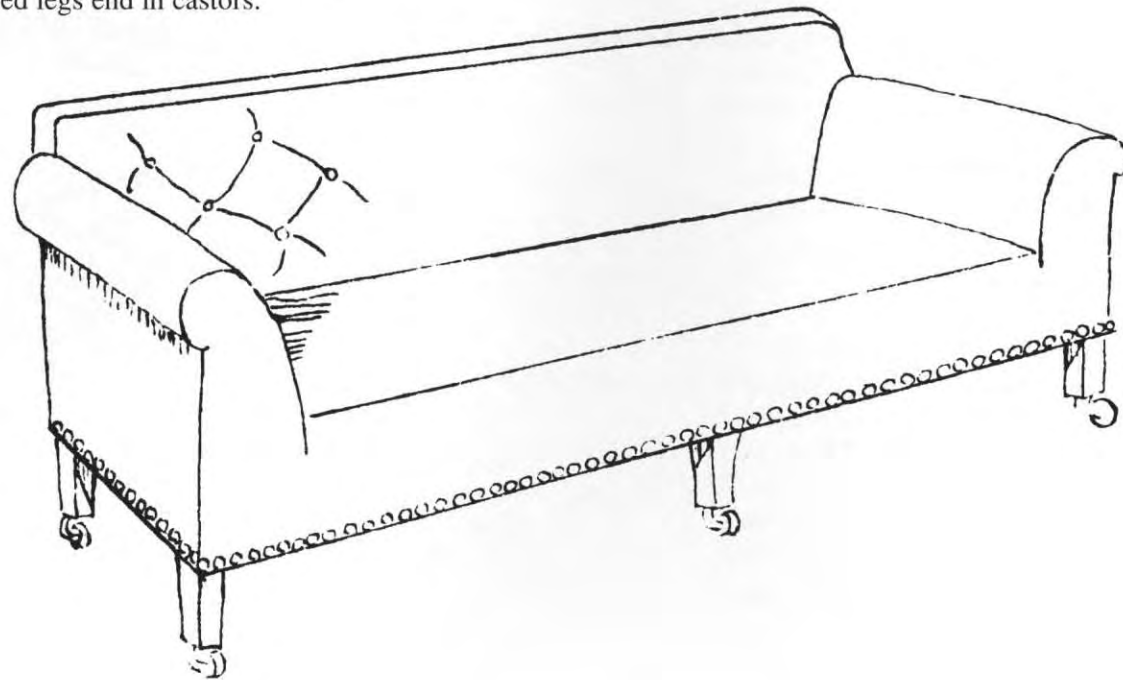

STYLE: GALLERY CHAIRS

MAKER: American School Furniture Company, Chicago, Illinois

MEASUREMENT: 94h x 44w x 38d

DESCRIPTION: The gallery chairs in the House Chamber were upholstered in brown imitation leather and arranged in rows of approximately ten chairs each. A rectangular backrest widens at the top and is supported by elongated cast-iron brackets extending from the reverse side. Narrow, inscribed wooden arms extend out from the midpoint of the stiles, and each ends in a small scroll. The small, square upholstered seat, which pivots from a sitting to an upright position, is supported by iron brackets directly below the seat. Brackets with simple scrolls and floral designs ornament the lower half of the end chairs in each row. Between each chair is a simpler version of the support bracket. The cast-iron brackets are electroplated with brass.

HISTORY: Purchased by Cass Gilbert for galleries in the House and Senate Chambers

1905 ORDER: 510

1989 TOTAL : 102

LOCATION: Capitol, House Gallery (92)  
Capitol, House Storage (10)

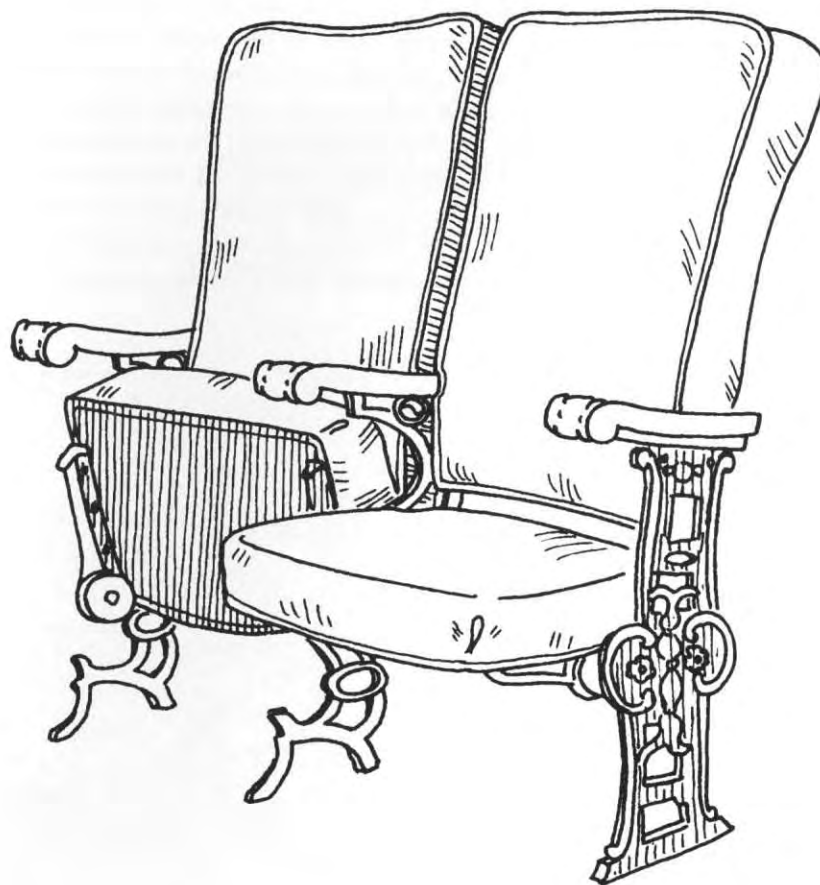

STYLE: W SOFA

MAKER: Unknown

MEASUREMENT: 110h x 240w x 66d  
110h x 212w x 67d

DESCRIPTION: The W mahogany or oak camelback sofa is upholstered in brown leather with the reverse side of the backrest outlined with 2-cm brass tacks. The front of the backrest is flanked by decorative wood stiles topped by carved scrolls. Broad, flat wooden armrests with molded edges extend out from the center of the stiles. Scrolled arm supports meet the plain, rectangular seat. The seat upholstery extends over the skirt and is outlined with 2-cm brass tacks. The

four corner legs are extensions of the back stiles and front arm supports. Front and rear center legs ending in block feet are attached to the center of the skirt.

HISTORY: Designed by Cass Gilbert for House Chamber, minor House corridors and several anterooms

1905 ORDER: 15  
1989 TOTAL : 12

LOCATION: American Center Building, 7th Floor, Public Utilities (1)  
Capitol, near G24, Southeast Corridor (1)  
Capitol, 218 (1)  
Capitol, 2nd Floor Corridors (4)  
Capitol, House Retiring Room (4)  
State Office Building, 155 Lobby (1)

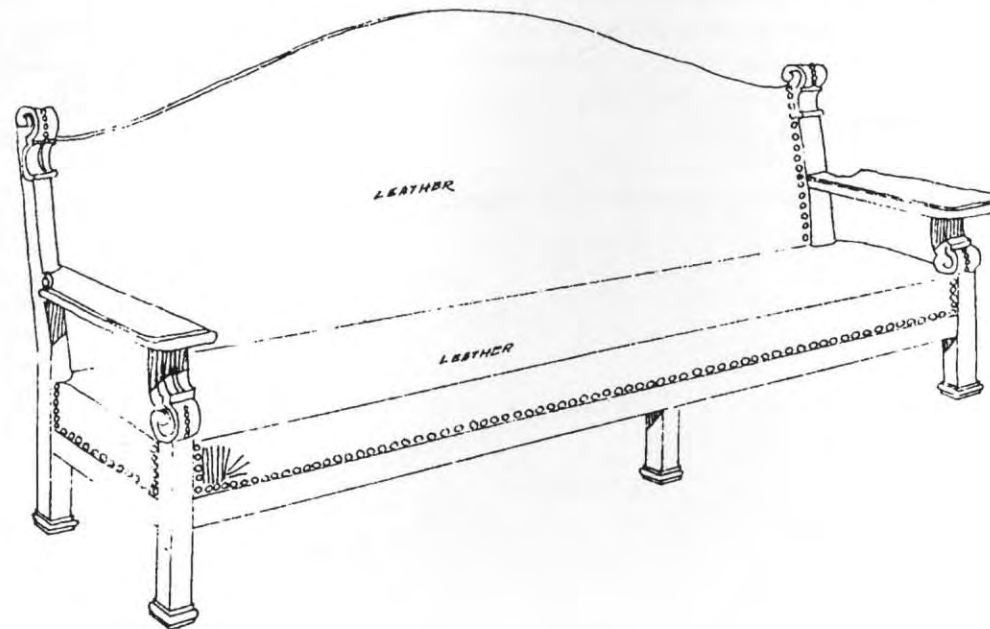

STYLE: CHAISE LOUNGE  
MAKER: Herter Brothers, New York, New York  
MEASUREMENT: 62h x 192w x 75d

DESCRIPTION: The brown leather-upholstered chaise lounge has a large, cylindrical upholstered headrest 72-cm wide and 25 cm in diameter and outlined with welting. The upholstered seat is plain and rectangular. The upholstery extends over the seat rail and is outlined with welting and 2-cm brass tacks. The plain, tapered legs end in small wooden castors.

HISTORY: Requested by justices in January 1905 after Herter contract was completed, designed by Cass Gilbert

1905 ORDER: 5  
1989 TOTAL : 1

LOCATION: Capitol, B59 (1)

*This rough sketch, apparently by Gilbert, was attached to a letter from Justice Edward Jaggard dated January 1905, now in the Cass Gilbert Papers, Archives and Manuscripts, Minnesota Historical Society.*

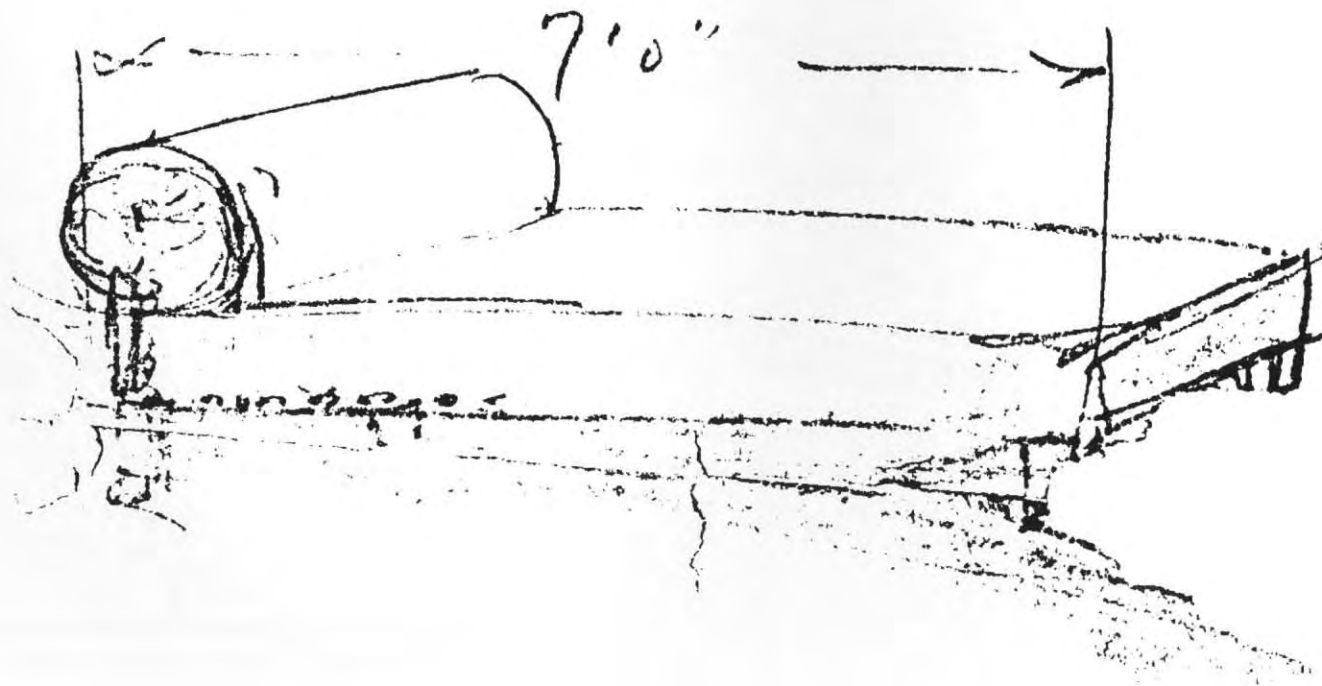

STYLE: AE SETTEE

MAKER: B. Burnett, probably New York, New York

MEASUREMENT: 105h x 243w x 58d

DESCRIPTION: The AE mahogany or oak settee has a molded top rail\* consisting of carved reeding and cross ties ending in a carved scroll. The backrest has three rectangular recessed panels of equal size. The plain seat has simple molded edging. Armrests slope down in a scroll design to rounded handholds. Three stan-

dards, each with scrolled knees ending in claw feet, are joined by a plain, flat central support stretcher.

HISTORY: Designed by Cass Gilbert for Supreme Court Chamber (mahogany) and Room 209-House Lobby (oak)

1905 ORDER: 8 (plus 2 reproductions, 1974)

1989 TOTAL : 10

LOCATION: Capitol, 2nd Floor, East Corridor (1)  
 Capitol, 2nd Floor, North Corridor (1)  
 Capitol, Supreme Court Chamber (8)

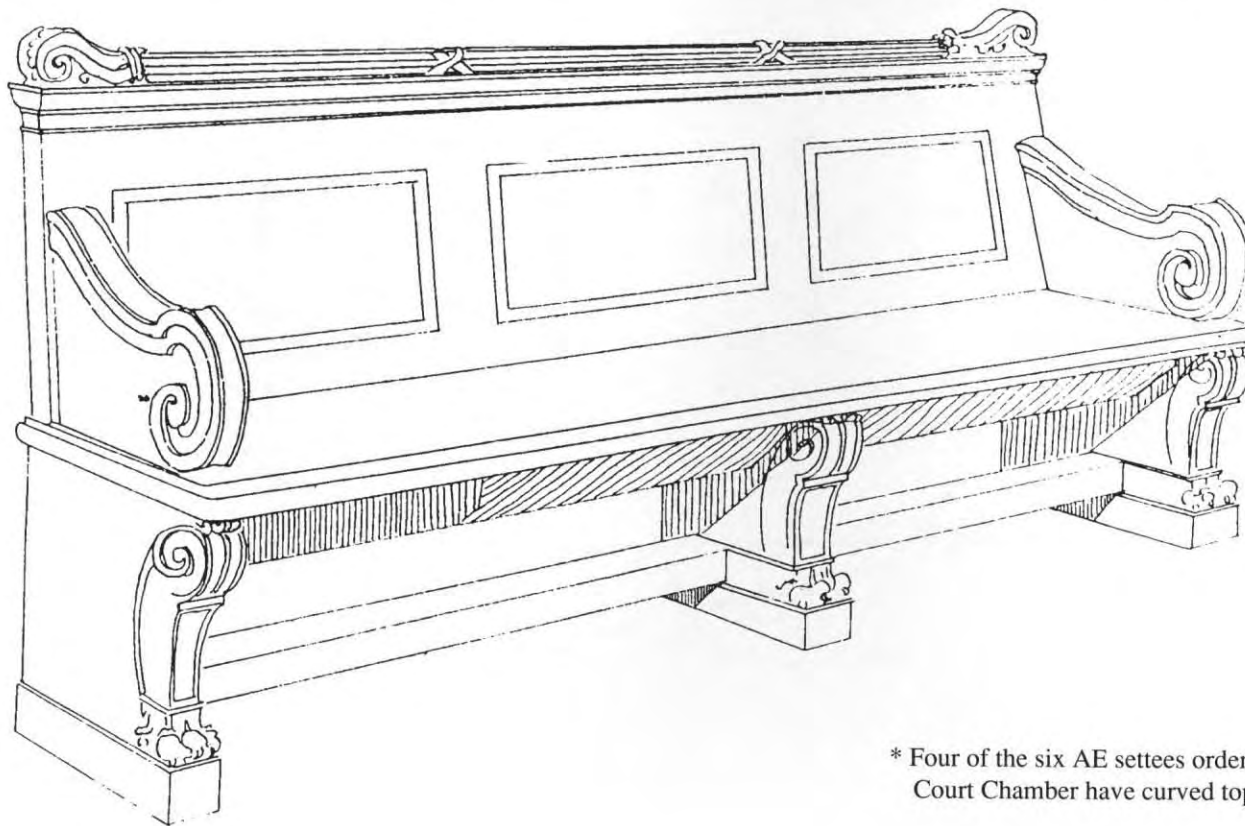

\* Four of the six AE settees ordered for the Supreme Court Chamber have curved top rails and seats.

STYLE: WY SETTEE

MAKER: Passman & Dauere, New York, New York

MEASUREMENT: 78h x 198w x 59d

DESCRIPTION: The WY American quartersawn white oak settee has a continuous straight topped back and arms of equal height. Its molded top rail, ornamented with narrow, incised acanthus trim, adjoins the plain, rectangular back. The front of each arm support is C-scrolled at the top and bottom and contains simple leaf carving. A detailed geometric design with dark wood inlay decorates the exterior sides of the arm panels. The plain, wooden seat has molded edging. The skirt is outlined with an incised wave-scroll pattern. The

standard fronts are scrolled at top and bottom and have acanthus ornamentation at the knees. Each standard sits upon a plain, flat rectangular base.

HISTORY: Designed by Cass Gilbert for First Floor Corridors

1905 ORDER: 14

1989 TOTAL : 14

LOCATION: Capitol, Northwest Ground Entrance (1)  
Capitol, 1st Floor, Rotunda, (5)  
Capitol, 1st Floor, West Corridor (4)  
Capitol, 1st Floor, East Dome Corridor (2)  
Capitol, Senate Lobby (2)

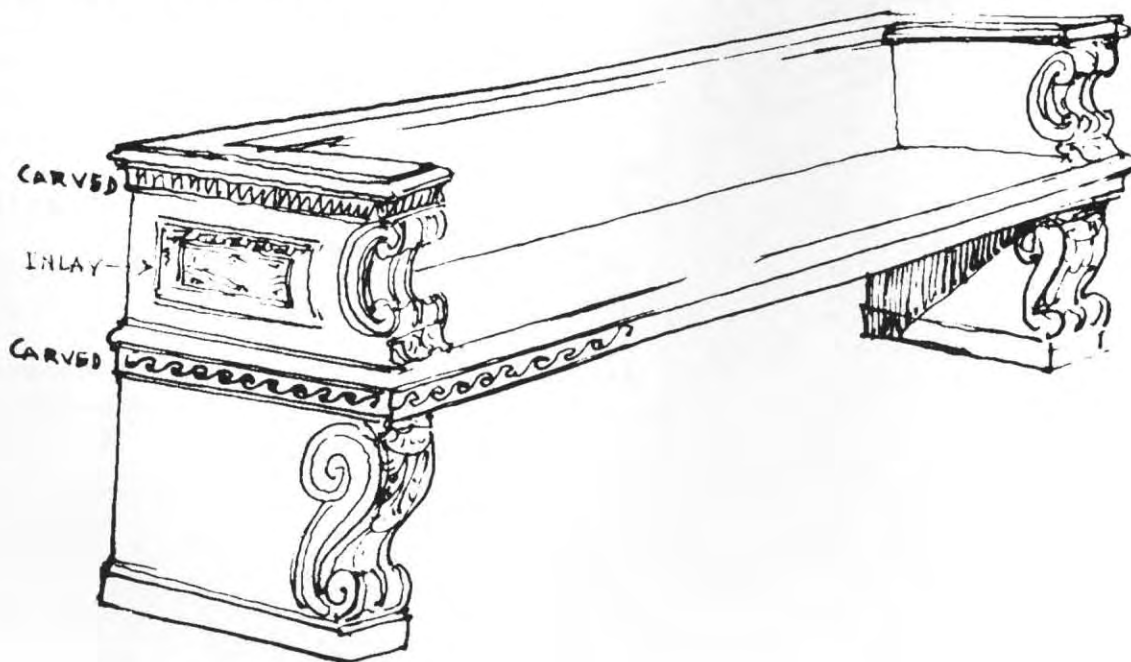

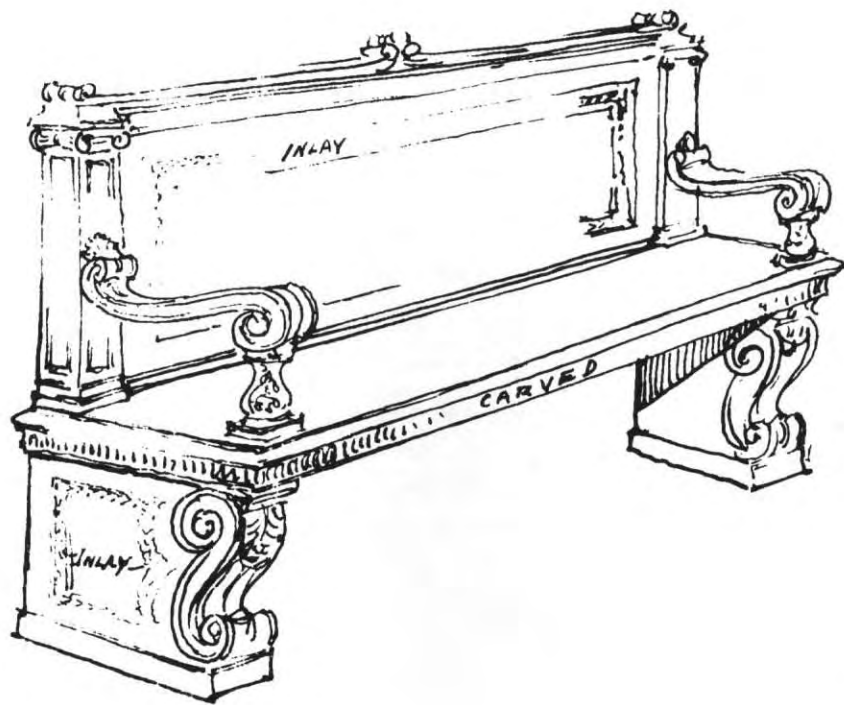

STYLE: WX SETTEE

MAKER: Passman & Dauere, New York, New York

MEASUREMENT: 104h x 198w x 58d

DESCRIPTION: The WX English oak settee has a top rail ornamented with scrolled, fluted molding and a center palmette bordered by scroll-leaf carving. The front of the backrest is outlined with detailed acorn, leaf, and ribbon inlay and is flanked by pilaster-shaped stiles topped by Ionic capitals. Carved open armrests extend out from the midpoint of the stiles, where they are ornamented with a single acanthus leaf. The armrests widen to scrolled handholds. The bulbous arm supports are decorated with carved acanthus leaves. The wooden seat is plain and flat with simple molded edging. The skirt is decorated with an incised scoop pattern. Leaf carving adorns the front knees of the scrolled standards. Acorn inlay decorates the exterior sides.

HISTORY: Designed by Cass Gilbert for 2nd Floor Corridors

1905 ORDER: 8

1989 TOTAL : 8

LOCATION: Capitol, 2nd Floor, West Corridors (7)  
Capitol, Governor's Anteroom (1)

STYLE: WV BENCH

MAKER: Hajek Marble Company, New York, New York

MEASUREMENT: 49h x 198w x 50d

DESCRIPTION: The WV Skyros marble bench has a solid marble rectangular seat 8 cm high and 198 cm wide. A carved scroll adorns the sides and fronts of each standard end. An acanthus leaf ornaments the knee of each scroll. The exterior recessed panel on each standard has a central palmette carving just above the rectangular base.

HISTORY: Designed by Cass Gilbert for the 2nd Floor Capitol Rotunda

1905 ORDER: 4

1989 TOTAL : 4

LOCATION: Capitol, 2nd Floor, Rotunda (4)

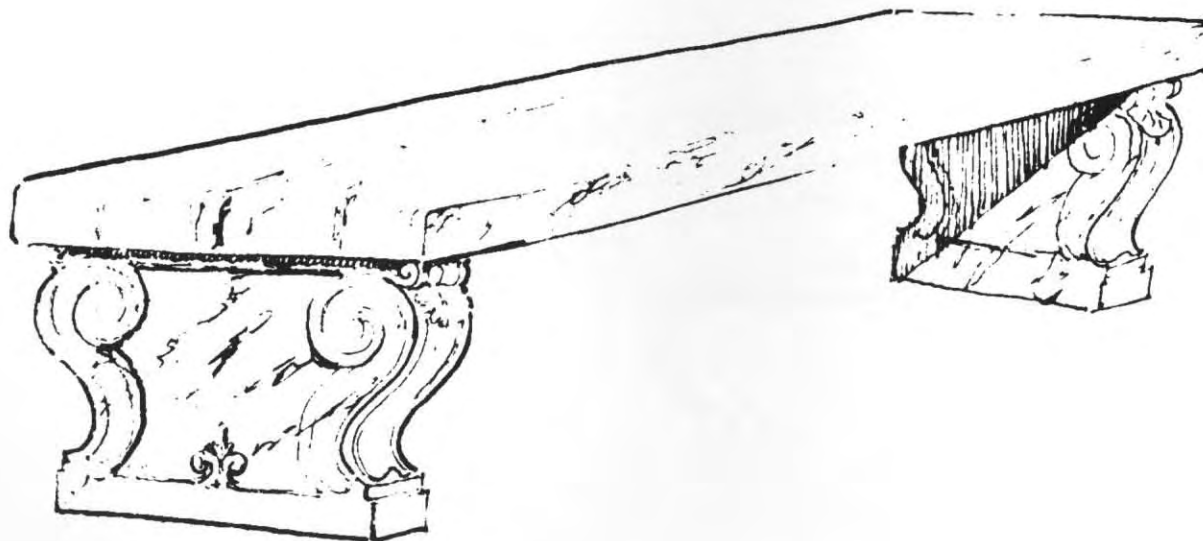



STYLE: WZ BENCH

MAKER: Probably Marble & Shattuck Chair Company,  
Cleveland, Ohio

MEASUREMENT: 46h x 228w x 50d

DESCRIPTION: The WZ quartersawn white oak bench has a plain, flat rectangular seat and narrow skirt supported by two paneled standards that narrow and then curve out slightly near the floor. The front and reverse of each standard are decorated with a simple, carved waterleaf set within a frame.

HISTORY: Designed by Cass Gilbert for Ground and 3rd Floor  
Corridors

1905 ORDER: 10

1989 TOTAL : 9

LOCATION: Capitol, B4 (1)  
Capitol, Basement Tunnel (1)  
Capitol, 3rd Floor Corridors (5)  
Minnesota Historical Society, 690 Cedar Street,  
Front Lobby (2)

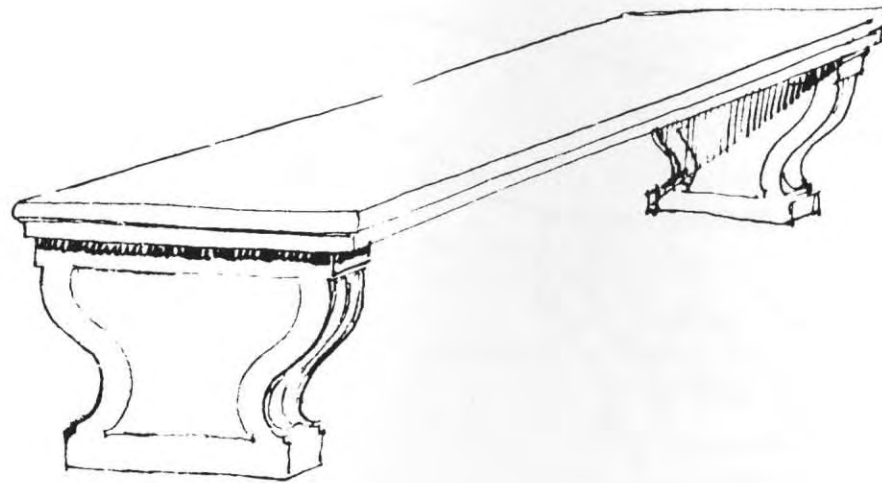

STYLE: AD TESTIMONIAL TABLE

MAKER: Herter Brothers, New York, New York

MEASUREMENT: 97h x 210w x 82d

DESCRIPTION: The AD mahogany table has a flat, rectangular surface with molded edging consisting of carved reeds and cross ties with a recessed skirt and center shelf. Each cabriole leg is ornamented with a carved lion head at the top and acanthus decor at the knee. The lower portion of each leg resembles an animal's leg and ends in a claw foot. The claw feet rest upon plain, flat side stretchers that connect with a central, plain, flat support stretcher.

HISTORY: Designed by Cass Gilbert for the Supreme Court Chamber

1905 ORDER: 1

1989 TOTAL : 1

LOCATION: Capitol, Supreme Court Chamber (1)

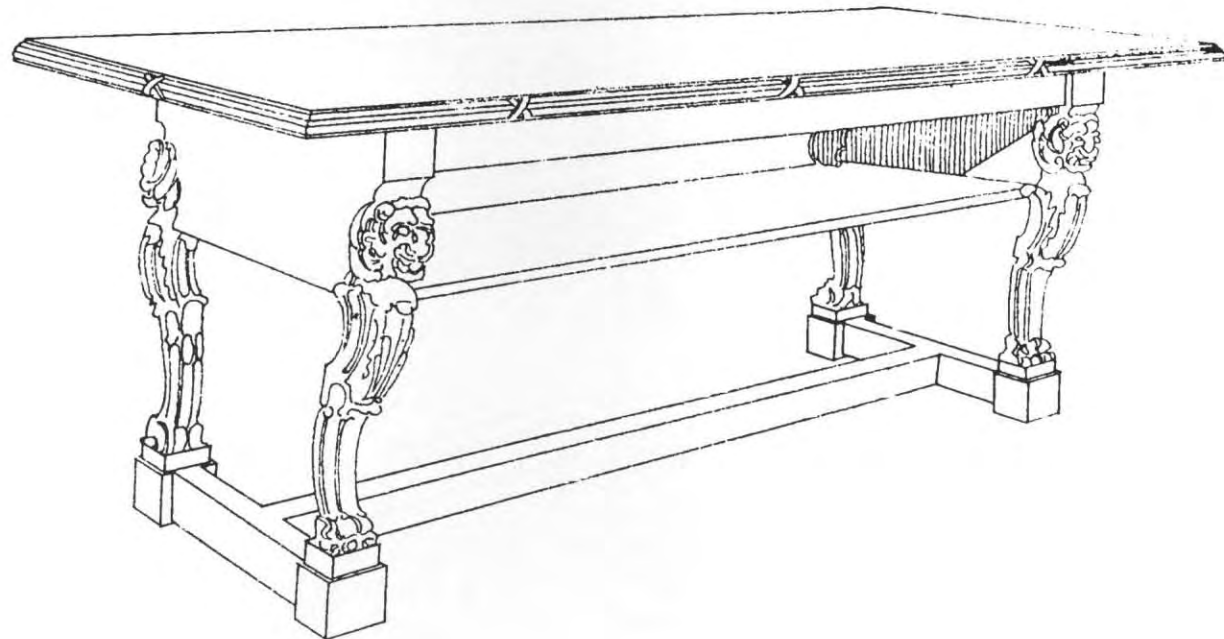

STYLE: AH Conference Table

MAKER: Catok & Beller, New York, New York

MEASUREMENT: 80h x 366w x 152d

DESCRIPTION: The AH mahogany table has a rectangular, flat surface with convex molded edging, a plain narrow skirt, and five large turned legs. Below the bulbous section of each leg is carved acanthus ornamentation. Each bun foot is topped by a block with floral carving on all four sides. Bowed, plain, flat side stretchers meet the central support stretcher, intersecting the fifth leg.

HISTORY: Designed by Cass Gilbert for the Supreme Court Consultation Room

1905 ORDER: 1

1989 TOTAL: 1

LOCATION: Capitol, Court Consultation Room (1)

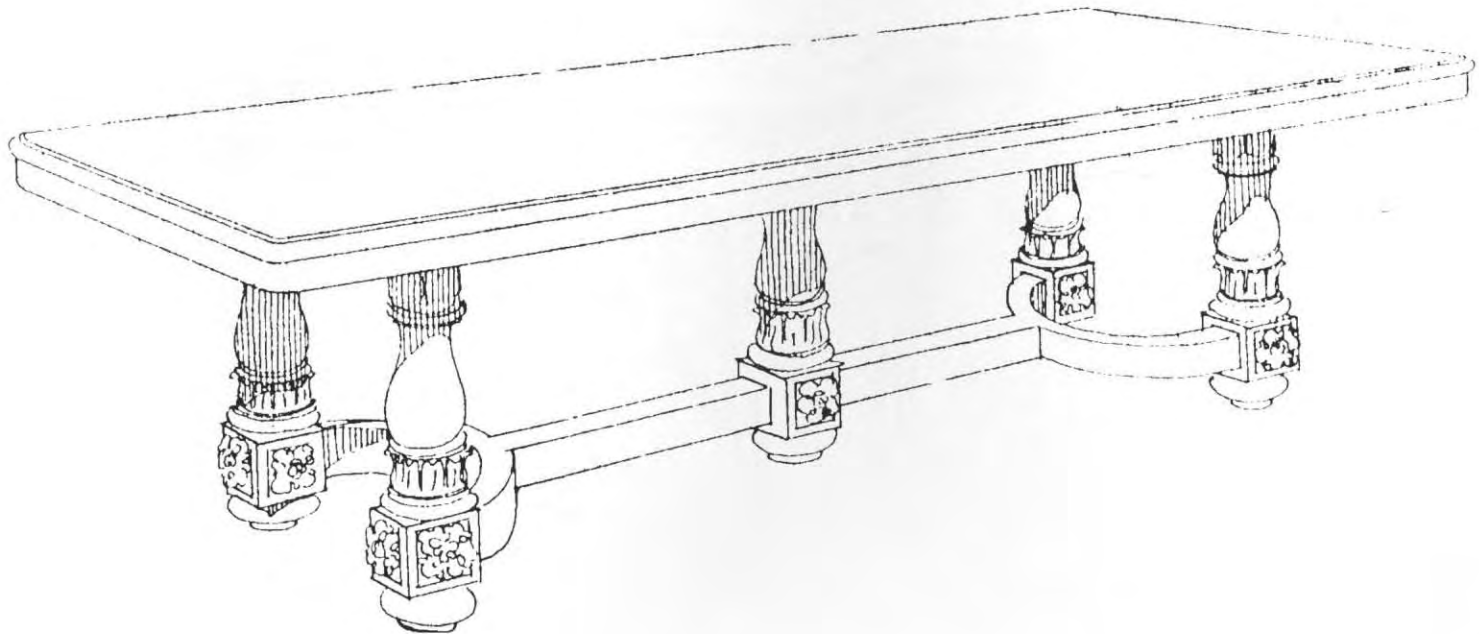

STYLE: AJ WORK TABLE  
MAKER: F. Mohr & Company, New York, New York  
MEASUREMENT: 78h x 181w x 90d

DESCRIPTION: The AJ mahogany table has a flat, rectangular surface with molded edging. The end standards are vase-shaped and scrolled at the top. The mid-point of each standard (along the exterior edge) is ornamented with carved acanthus leaves extending down to a molded base and distinctive claw feet. The end standards are joined by a plain, flat center stretcher.

HISTORY: Designed by Cass Gilbert for the Governor's Secretarial Office and the Governor's Private Office

1905 ORDER: 2  
1989 TOTAL : 2

LOCATION: Capitol, 102D (1)  
Capitol, House Retiring Room (1)

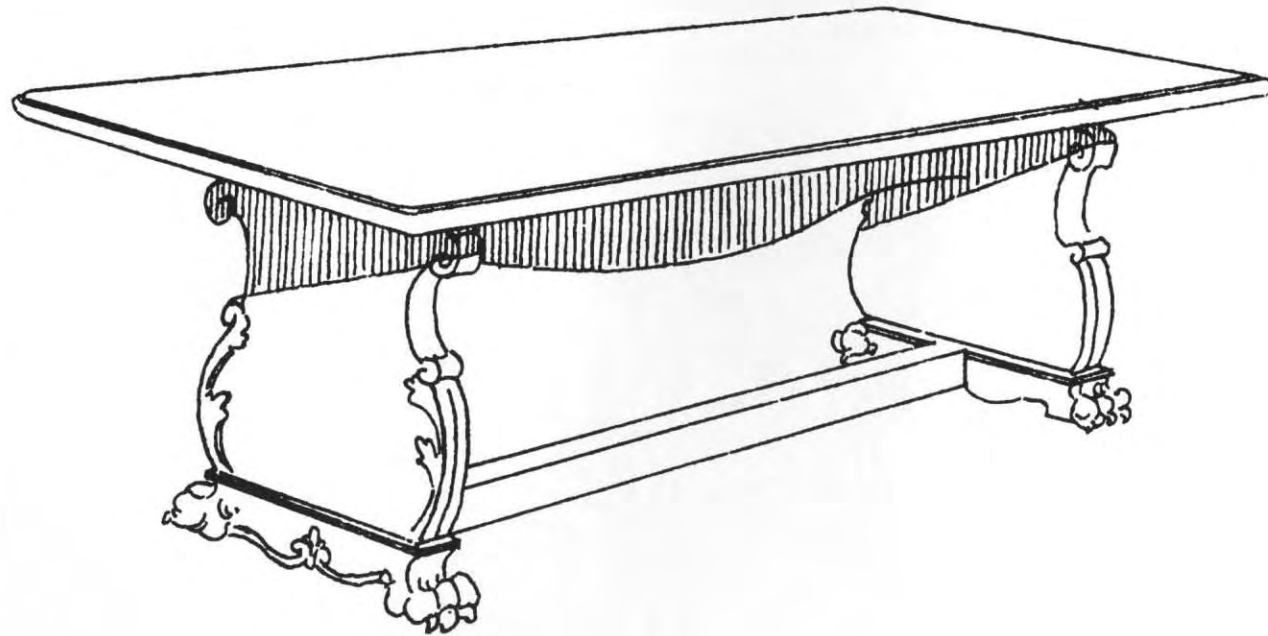

STYLE: AL WORK TABLE

MAKER: F. Mohr & Company, New York, New York

MEASUREMENT: 79h x 242w x 120d

DESCRIPTION: The AL mahogany work table has a flat, rectangular surface with molded edging. The front table skirt contains two drawers of equal size, each with two round brass pulls. The skirt ends are carved panels with foliage-scroll motif carving along the bottom edges and around a central palmette carving. The cabriole legs are scrolled at the top and ornamented with acanthus decor on the knee. The legs end in block sections and bun feet. The fifth leg (under center of table) is columnar, tapered, and turned at top and bottom.\* The bowed side stretchers meet a plain, flat center support stretcher.

HISTORY: Designed by Cass Gilbert for the Governor's Business Office and the Reception Room

1905 ORDER: 2

1989 TOTAL : 2

LOCATION: Capitol, Governor's Formal Office (1)  
State Office Building , 174 (1)

\* The design of the AL table was altered slightly from Cass Gilbert's circa 1903 drawing.

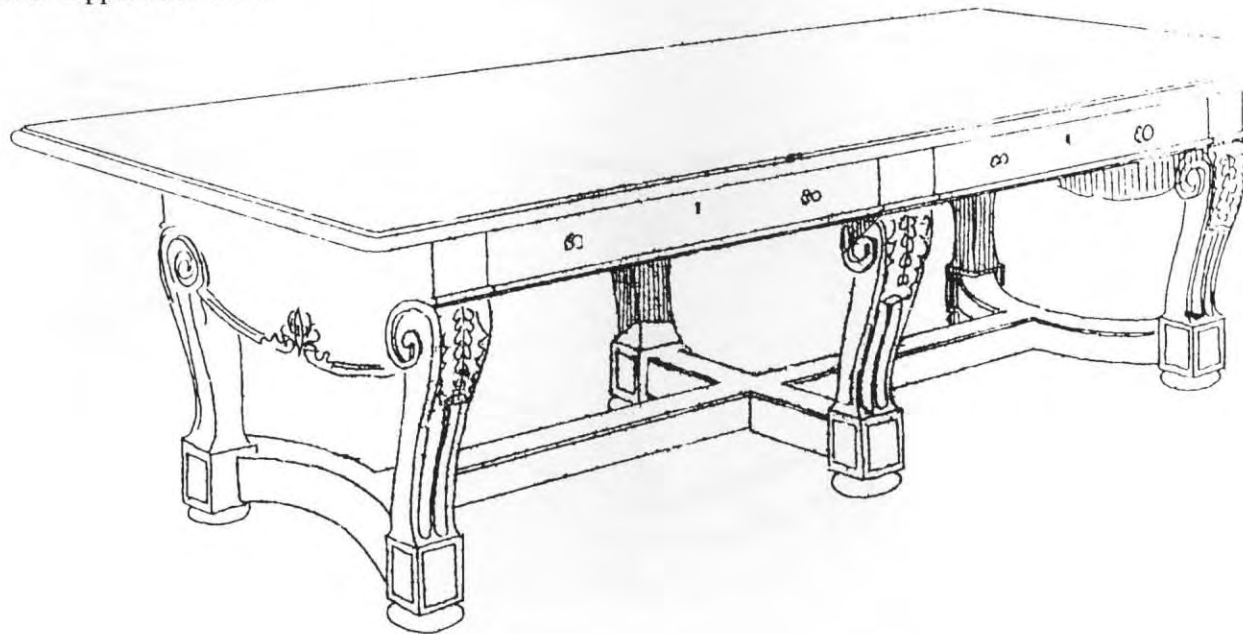

STYLE: AO CONFERENCE TABLE

MAKER: Herter Brothers, New York, New York

MEASUREMENT: 79h x 310w x 140d

DESCRIPTION: The AO mahogany oval table has a plain surface edged with convex inscribed molding. The eight scroll-top legs have detailed acanthus ornamentation carved on each knee. The bun feet are topped by square blocks with a rosette design carved on three sides of the blocks. The fourth sides of the blocks are attached to one of a series of straight and curved stretchers that connect the legs, creating a geometric design.

HISTORY: Designed by Cass Gilbert for the Governor's Reception Room

1905 ORDER: 1  
1989 TOTAL : 1

LOCATION: Capitol, Governor's Reception Room (1)

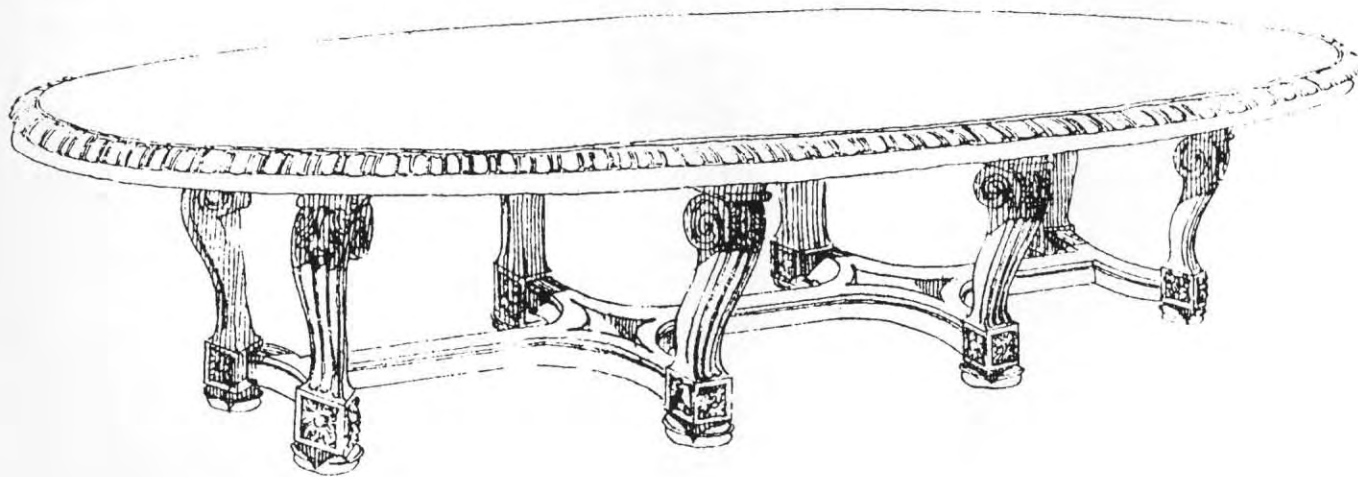

STYLE: BB WORK TABLE

MAKER: F. Mohr & Company, New York, New York

MEASUREMENT: 77h x 243w x 100d

DESCRIPTION: The BB mahogany table has a flat, rectangular surface with a three-tier molded edge ornamented with eight cross-tie carvings. The elaborately carved standards include an acanthus leaf design flanking a central carved, stylized pineapple figure. Each standard sits on a simple, rectangular molded base.\* The two bases are connected by a flat, central support stretcher.

HISTORY: Designed by Cass Gilbert for the House of Representatives Chamber

1905 ORDER: 2

1989 TOTAL : 1

LOCATION: Capitol, Governor's Private Office (1)

\* The design of the base was altered from Gilbert's circa 1903 drawing.

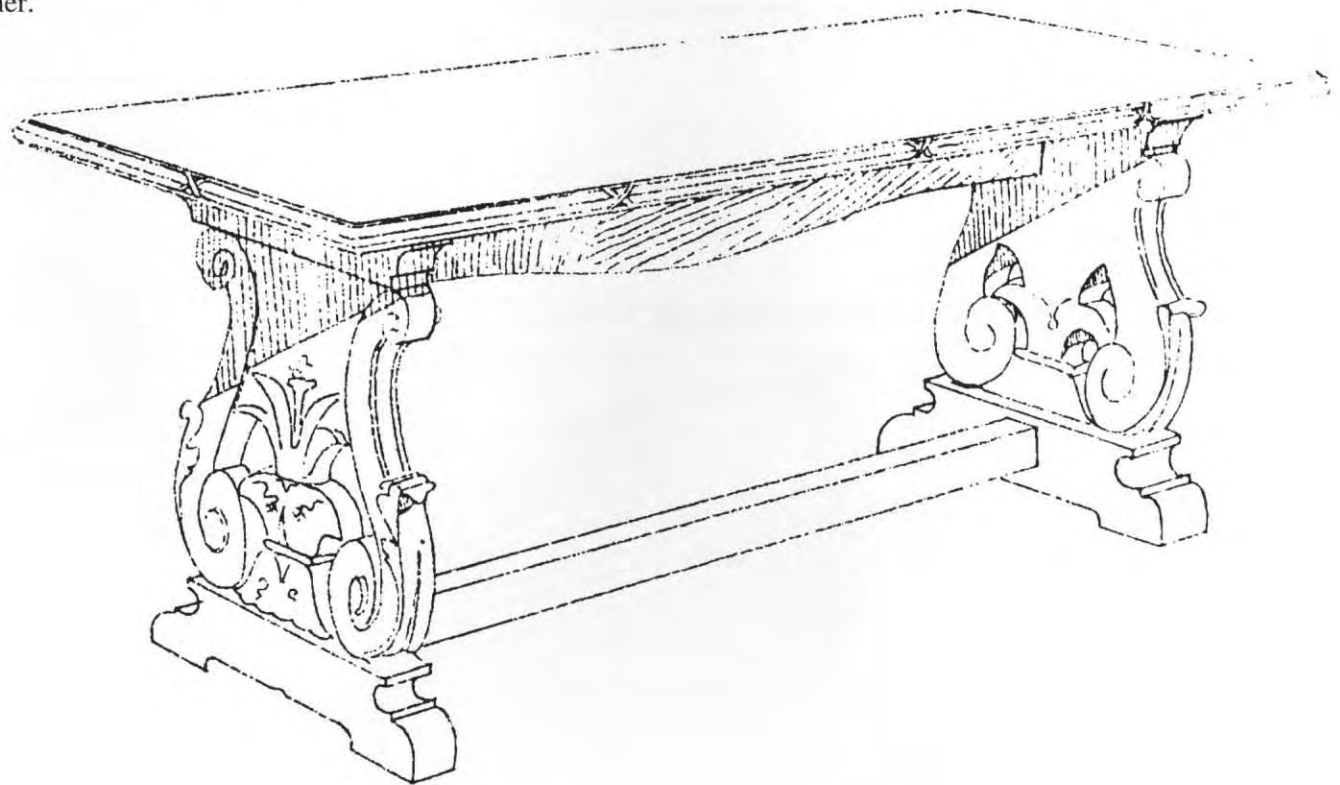

STYLE: GG CONFERENCE TABLE

MAKER: Herter Brothers, New York, New York

MEASUREMENT: 79h x 305w x 122d

DESCRIPTION: The GG mahogany table has a large, rectangular surface with molded edging, supported by two ornate end standards. The exterior side of each standard has a central, recessed rectangular panel, and the design is repeated on the single, central support panel, which is stabilized by a scrolled cross tie. A carved swag, ornamenting the upper half of each panel, joins the carved C-scrolls flanking the central panel. The reverse S-scrolls extend down to a rectangular base ornamented with foliage carving and scrolled at both ends. A flat, molded central support stretcher connects the central support panel and end standards.

HISTORY: Designed by Cass Gilbert for the Senate Retiring Room

1905 ORDER: 1

1989 TOTAL : 1

LOCATION: Capitol, Senate Retiring Room (1)

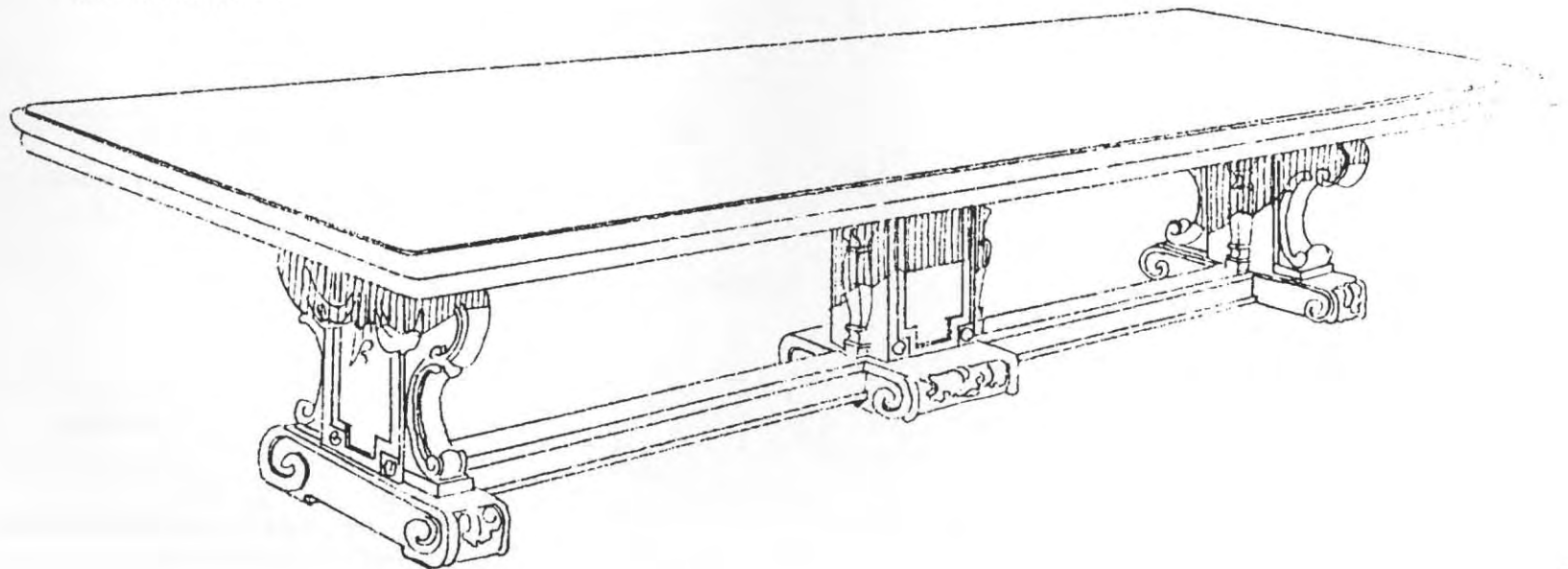



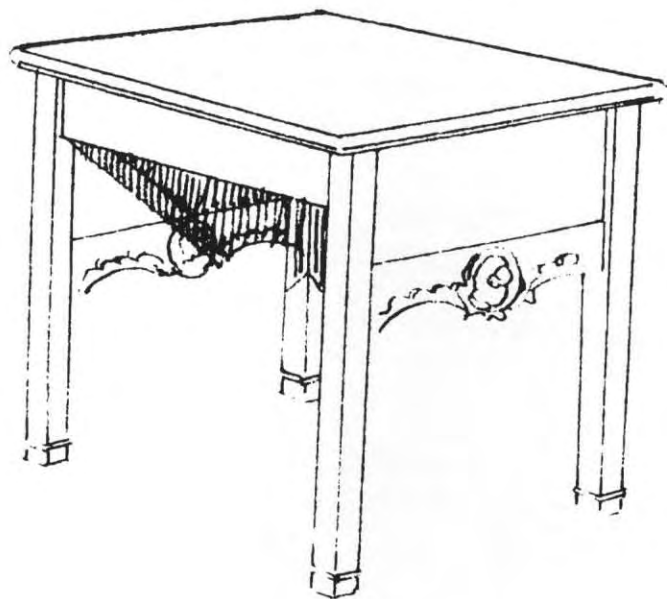

STYLE: LL Drinking Table

MAKER: F. Mohr & Company, New York, New York, or  
Stillwater Manufacturing Company, Stillwater,  
Minnesota

MEASUREMENT: 76h x 54w x 67d

DESCRIPTION: The LL mahogany drinking table has a flat, rectangular surface with molded edging. The tall front and rear skirts are decorated with floral-scroll-leaf designs in the center.\* The shorter side skirts are plain and flat. The tapered legs end in plain, molded brackets.

HISTORY: Designed by Cass Gilbert for the Senate Retiring Room, minor House Corridors and the Supreme Court Consultation Room

1905 ORDER: 5 (plus 2 reproductions 1989)  
1989 TOTAL : 5

LOCATION: Capitol, 214 (1)  
Capitol, 223 (1)  
Capitol, Court Consultation Room (1)  
Capitol, Governor's Reception Room (2)

\* The design of the table was altered slightly from Gilbert's circa 1903 drawing.

STYLE: N Work Table

MAKER: Bohn Manufacturing Company, St. Paul, Minnesota

MEASUREMENT: Varies in length and width

DESCRIPTION: The mahogany or oak N table, used as a working or conference table, has a flat, rectangular surface with molded edging.\* The plain skirt may contain two, three, or four drawers of equal size with oblong wooden finger grips. Plain, tapered legs adjoin two bowed stretchers meeting a plain, flat center support stretcher.

HISTORY: Designed by Cass Gilbert for offices throughout the Capitol

1905 ORDER: 100  
1989 TOTAL : 35

LOCATION:

- Capitol, B59 (2)
- Capitol, B60 (3)
- Capitol, Tunnel, near B55C (1)
- Capitol, Ground Floor, North Corridor (1)
- Capitol, Ground Floor, West Vestibule (2)
- Capitol, G9 (1)
- Capitol 121 (1)
- Capitol, 2nd Floor, near 204 (1)
- Capitol, 3rd Floor, near 324(1)
- Capitol, 315 (1)
- American Center Building, 7th Floor, Public Service (1)
- American Center Building, 7th Floor, Public Utilities (1)
- Fort Snelling, Minnesota Historical Society Archaeology Department (2)
- Hastings Veterans Home, Activity Room (1)
- James J. Hill House, 2nd Floor, Conference Room (1)
- Minnesota Historical Society, 690 Cedar Street, 1st Floor, Map Library (2)
- Minnesota Historical Society, 690 Cedar Street, Exhibits (1)
- Minnesota Historical Society, 690 Cedar Street, 2nd Floor, Publications Production Supervisor (1)
- State Office Building, G11 (3)
- State Office Building, G13 (2)
- State Office Building, 132C (1)
- State Office Building, 132D (1)
- State Office Building, 148 (1)
- State Office Building, 763 (1)
- Labor and Industry Building, Basement (2)

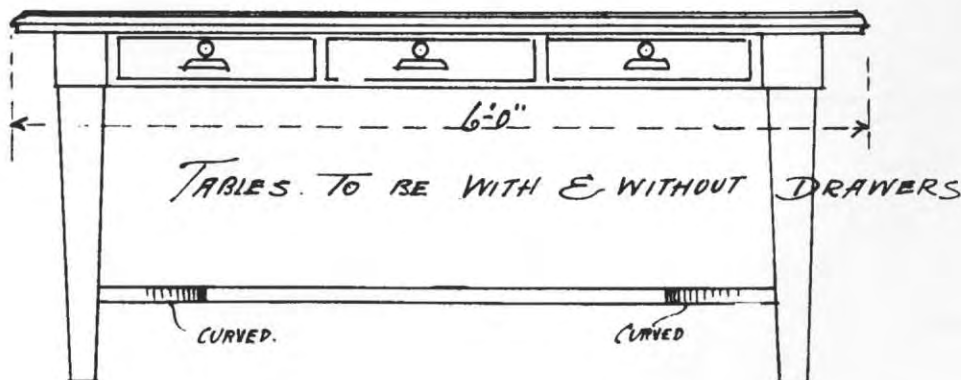

\* Several N tables have been resurfaced with green slate or wood-grain laminate.

STYLE: P LETTER PRESS TABLE

MAKER: Herter Brothers, New York, New York

MEASUREMENT: 80h x 96.5w x 60d

DESCRIPTION: The P oak letter press table has a flat rectangular top and plain skirt with a front central drawer with brass bin pull. The pull-out writing slides on each end of the table each have a small, round metal pull in the center. A plain, flat open shelf sits below the mid-point of the plain, flat tapered legs.

HISTORY: Designed by Cass Gilbert for offices throughout the Capitol

1905 ORDER: 10

1989 TOTAL : 1

LOCATION: Capitol, 318 (1)

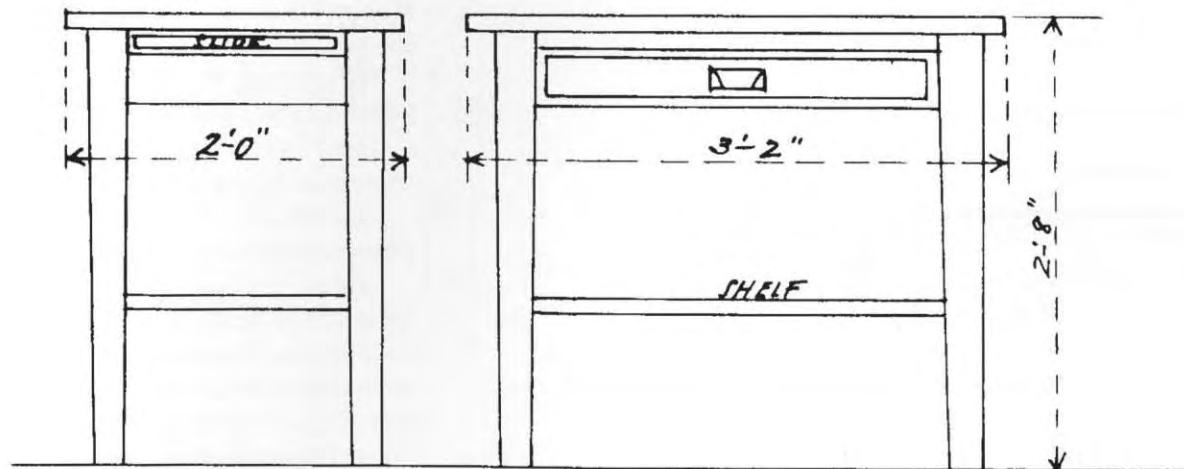

LETTER PRESS STAND

STYLE: YY WORK TABLE

MAKER: F. Mohr & Company, New York, New York

MEASUREMENT: 78h x 183w x 91d

DESCRIPTION: The YY mahogany table has a flat, rectangular surface with molded edging consisting of carved reeds and cross ties. The plain skirt is shorter on the sides than on the ends. A scrolled leg at each corner is carved with acanthus ornamentation at the knee. Bun feet are topped by simple rectangular blocks with recessed panels. Plain, flat side stretchers meet a central plain, flat support stretcher.

HISTORY: Designed by Cass Gilbert for the Senate Chamber and the Supreme Court Chamber

1905 ORDER: 4

1989 TOTAL : 4

LOCATION: Capitol, Senate Chamber (2)  
Capitol, Supreme Court Chamber (2)

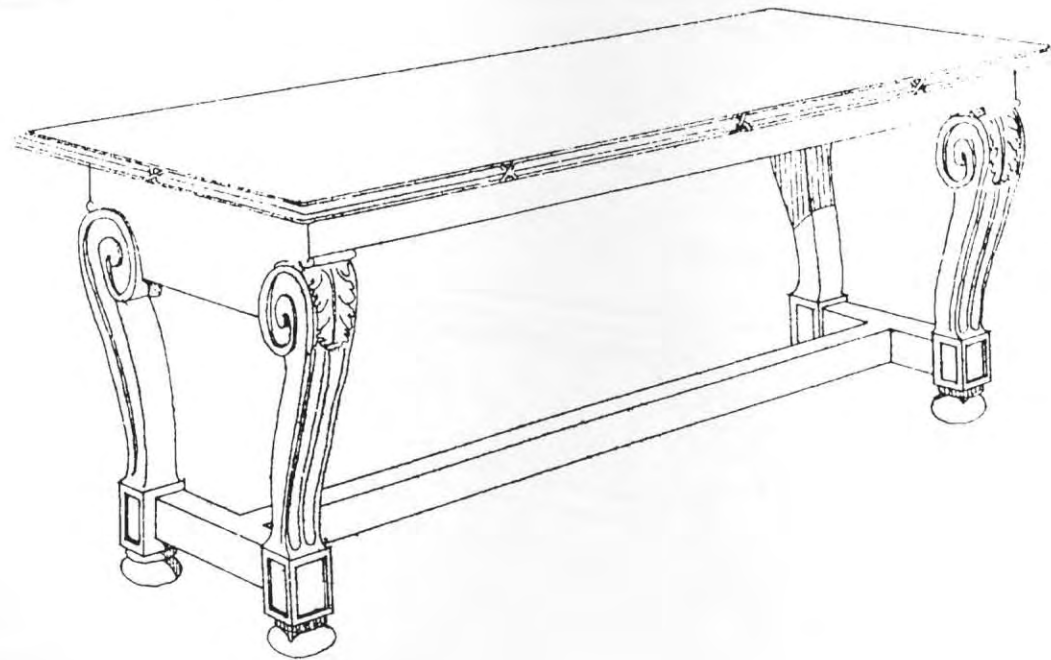

STYLE: ZZ CONFERENCE TABLE

MAKER: Catok & Beller, New York, New York

MEASUREMENT: 78h x 244w x 90d

DESCRIPTION: The ZZ oak conference table has a flat, rectangular surface with molded edging. The ends of the table have recessed skirts ornamented with acanthus carving. The six legs are a combination of blocks and turnings above and below an oval with acanthus motif. The large, flat side stretchers meet a central, flat support stretcher intersecting two equally spaced center legs. Each center leg is stabilized by a cross tie decorated with scrolls and acanthus leaf carvings. The legs and ends of the cross ties sit on bun feet.

HISTORY: Designed by Cass Gilbert for the House Retiring Room

1905 ORDER: 1

1989 TOTAL : 1

LOCATION: Capitol, House Retiring Room (1)

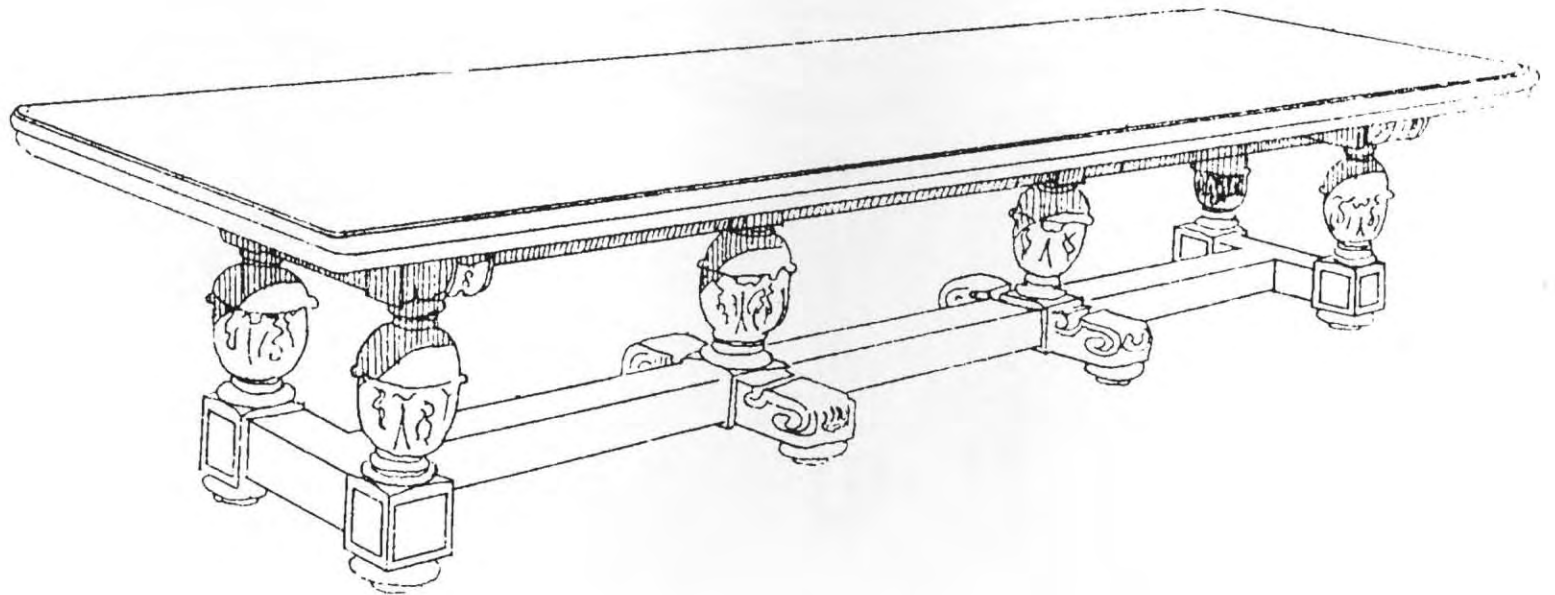

STYLE: AA SLANT-TOP DESK

MAKER: Doten & Dunton Desk Company, Boston, Massachusetts

MEASUREMENT: 86h x 91w x 61d

DESCRIPTION: The AA mahogany rectangular desk is topped by a sloped writing surface with a low, shaped splash-board at the front. The plain skirt has a central interior drawer directly above the kneehole. Below the central drawer are an open half-shelf and a small rectangular cabinet with paneled door. The double-paneled front is flanked by two pilasterlike stiles. The single-paneled sides adjoin standards, which are scrolled and ornamented with acanthus carving at the top. The standards curve in to meet a solid base.\*

HISTORY: Designed by Cass Gilbert for Senate and House Chambers

1905 ORDER: 188 (plus 13 reproductions circa 1913 and 4 reproductions circa 1959)

1989 TOTAL : 205

LOCATION: Capitol, House Chamber (135)  
Capitol, Senate Chamber (70)

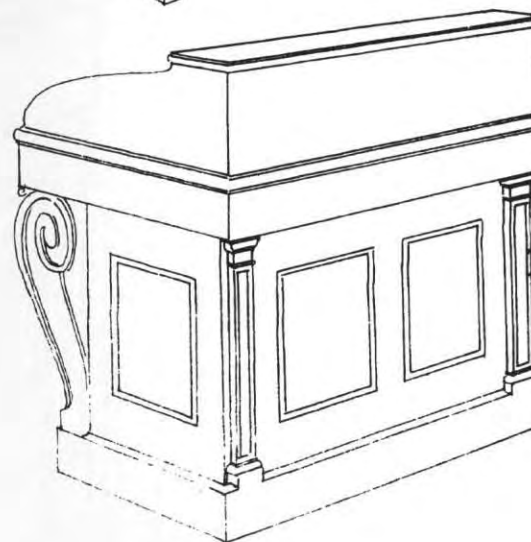
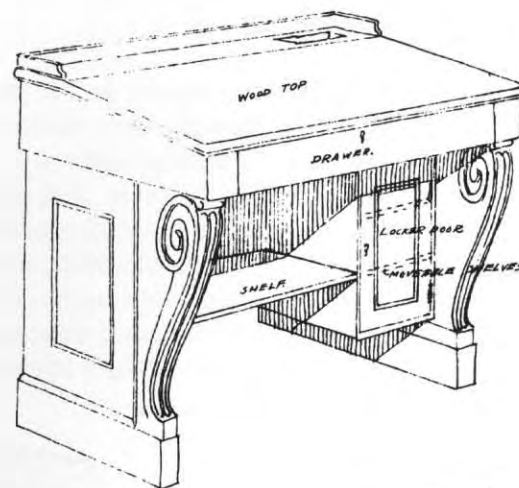

\* Alterations to the desks include removal of inkwells, rebuilding of drawers and storage cabinets, and drilling of holes to accommodate electrical wiring.

STYLE: AB SLANT-TOP DESK

MAKER: Herter Brothers, New York, New York

MEASUREMENT: 85h x 52w x 65d

DESCRIPTION: The AB mahogany rectangular desk is topped by a sloped writing surface with a low, shaped splash-board at the front. Two plain interior drawers with keyholes are above the kneehole. A double-paneled front is flanked by two pilasterlike stiles. The single-paneled sides adjoin standards, which are scrolled and ornamented with acanthus carving at the top. The standards curve in to meet a solid base. Along the interior of the base is an open half-shelf.

HISTORY: Designed by Cass Gilbert for the Supreme Court Chamber

1905 ORDER: 1

1989 TOTAL : 1

LOCATION: Capitol, Supreme Court Chamber (1)

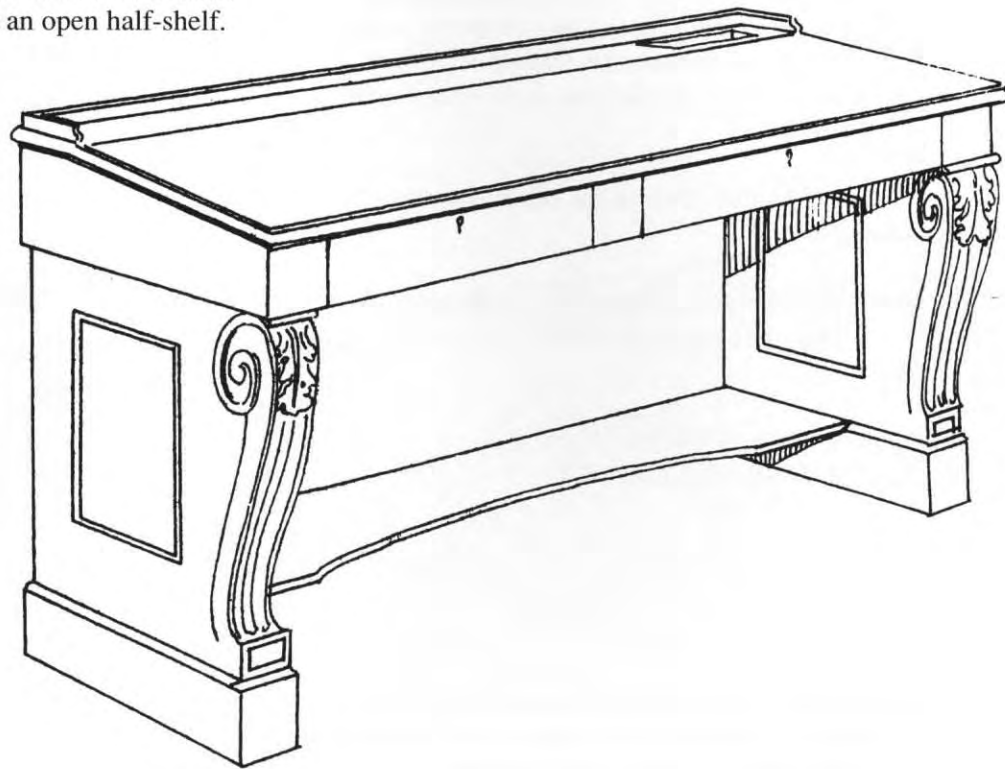

STYLE: C ROLLTOP DESK

MAKER: Derby Desk Company, Boston, Massachusetts

MEASUREMENT: 129h x 152w x 90d

DESCRIPTION: The C mahogany or oak two-piece desk has a tambour cover that rolls up to reveal a well with pigeonholes and drawers. The narrow top is molded and slightly overhanging, and it parallels the writing surface that divides the well from the lower pedestals. The roll top has rounded, recessed finger grips at the base and a center key surround that reads "DERBY DESK." The top center drawer beneath the writing surface has an oblong wooden finger grip and small key surround. The drawer is flanked by two pull-out writing slides with simple bronze handles. The left pedestal has four paneled drawers

with oblong finger grips. The right pedestal appears to have four drawers but contains only three; the bottom one is a file drawer. Rectangular panels of equal size are set in the sides of the desks and within the kneehole. The pedestals rest on a solid plinth base.

HISTORY: Purchased by Cass Gilbert for offices throughout the Capitol

1905 ORDER: 38

1989 TOTAL : 3

LOCATION: Capitol, Governor's Private Office (1)  
Capitol, Governor's Reception Room (1)  
9 East Aurora, 210, Plant Management (1)\*

\* Only the bottom half is extant at this location.

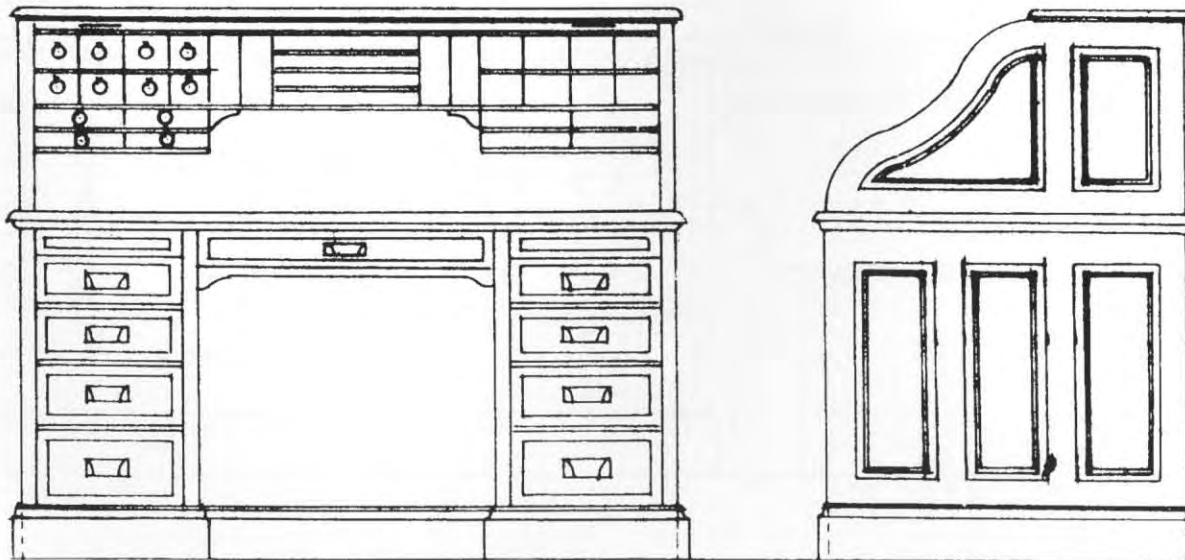



STYLE: D DOUBLE PEDESTAL DESK

MAKER: Grand Rapids Desk Company, Muskegon, Michigan

MEASUREMENT: 78h x 182w x 91d

DESCRIPTION: The D mahogany or oak double pedestal desk has a flat rectangular surface. The top center drawer has an oblong wooden finger grip and a small key surround and is flanked by two pull-out writing slides with scrolled bronze handles. The left and right pedestals each contain four drawers with raised fronts and oblong wooden finger grips. The top drawer in each pedestal contains a small round key surround. The sides and front of each pedestal have single-panel construction.\* The desk sits on a solid plinth base.

HISTORY: Purchased by Cass Gilbert for offices throughout the Capitol

1905 ORDER: 21 (plus 1 reproduction 1988)

1989 TOTAL : 3

LOCATION: Capitol, B44 (1)  
Capitol, 101 (1)  
Capitol, Governor's Anteroom (1)

\* The D double pedestal desk was altered slightly from Gilbert's circa 1903 specifications.

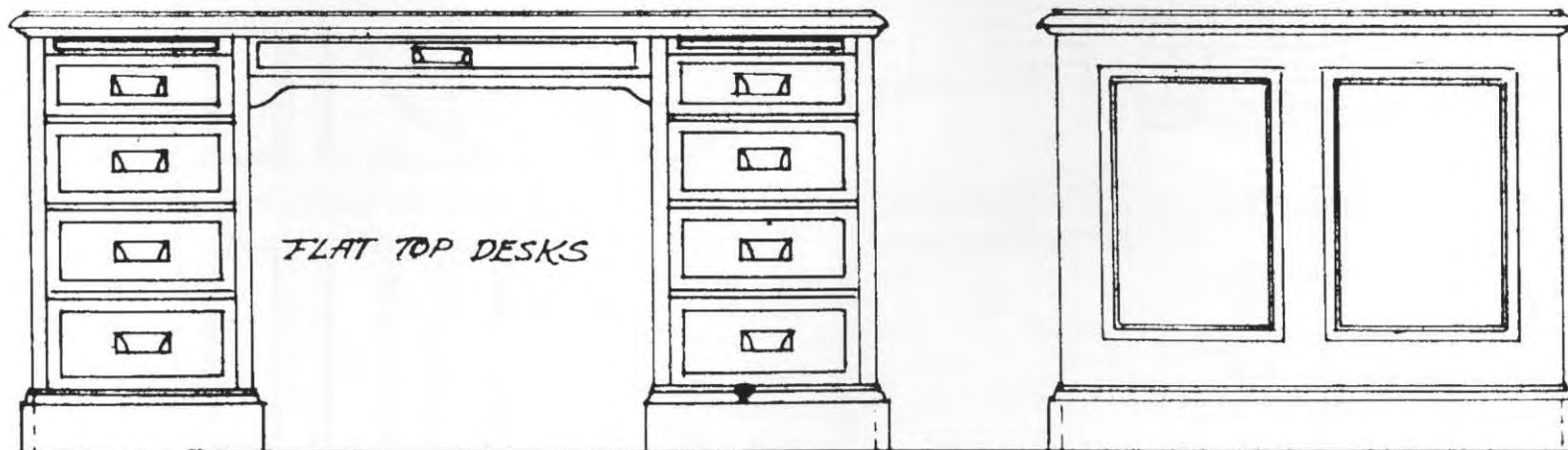

STYLE: HH DOUBLE WRITING DESK

1905 ORDER: 1

MAKER: F. Mohr & Company, New York, New York

1989 TOTAL : 1

MEASUREMENT: 77h x 123d x 85w

LOCATION: Capitol, Senate Retiring Room (1)

DESCRIPTION: The HH mahogany double writing desk has a flat, rectangular surface with a dividing backsplash 20 cm high. Above each kneehole is a single drawer with two brass bail handles. The upper portion of the skirt on either side of a center leg is plain and flat while the lower portion is curved and ornamented with carved acanthus leaves. The six tapered legs end in plain, molded brackets.

HISTORY: Designed by Cass Gilbert for the Senate Retiring Room

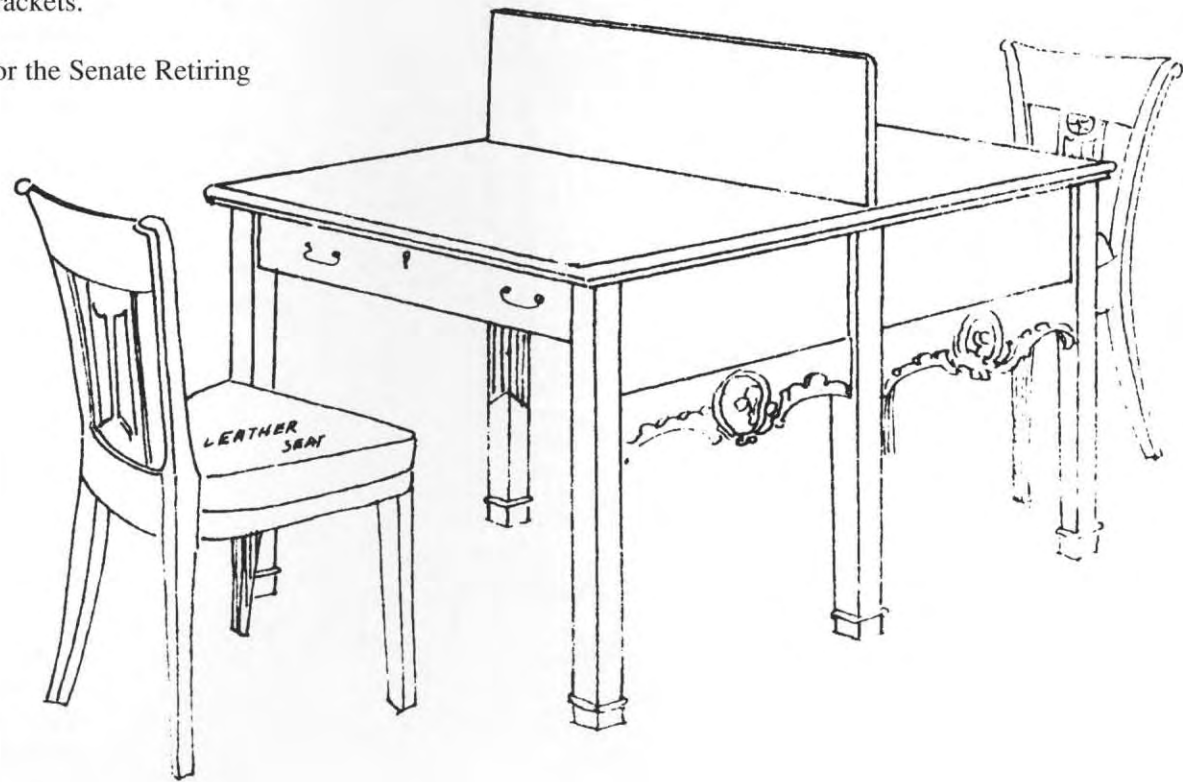

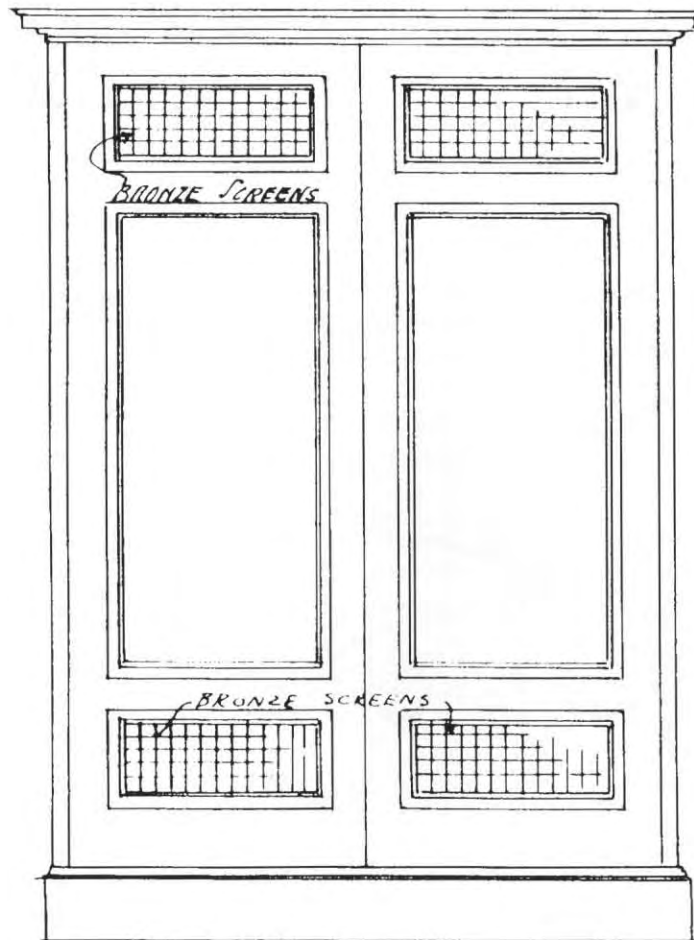

STYLE: Q WARDROBE

MAKER: Stillwater Manufacturing Company, Stillwater, Minnesota

MEASUREMENT: 198h x 46d (Width varies with number of doors.)

DESCRIPTION: The Q mahogany or oak compartmental wardrobe unit has a molded cornice and paneled doors attached with bronze hinges. Each door has bronze screens above and below a central rectangular panel with a molded border. Each door has a round metal key surround. The sides and back of the wardrobe have rectangular panels with molded borders, each corresponding to the length of the front panels and screens. The reverse side is stained but not varnished, and the entire unit sits on a plain plinth base.

HISTORY: Designed by Cass Gilbert for offices throughout the Capitol

1905 ORDER: 83

1989 TOTAL : 19

LOCATION: Capitol, B17E (1) Capitol, B59 (3)  
 Capitol, Tunnel, under East Stairs (2)  
 Capitol, Tunnel, near B55C (2)  
 Capitol, G9 (1)  
 Capitol, G20A, Southeast (1)  
 Capitol, near G31 (1) Capitol, 121 (1)  
 Capitol, 122 (1) Capitol, 217D (1)  
 Centennial, B22 Storage (1)  
 State Office Building, G17 (1)  
 State Office Building, across from Room G23 (1)  
 State Office Building, 132C (1)  
 Governor's Residence, Basement (1)

STYLE: REVOLVING BOOKCASE

MAKER: John Danner Manufacturing Company, Canton, Ohio

MEASUREMENT: 123h x 73w x 73d

DESCRIPTION: The oak or mahogany revolving bookcase has a plain, flat top with molded edging. The four sides each contain three shelves and five narrow, vertical slats extending from the top to a plain skirt near the bottom. The unit revolves on a vertical metal rod that runs through the center and joins the central metal support base. Four small wooden legs with simple metal ornamentation extend from the base and end in small wooden castors.

HISTORY: Purchased by Cass Gilbert for the Governor, the Attorney General, and Supreme Court Justices

1905 ORDER: 14  
1989 TOTAL : 2

LOCATION: Capitol, 102D (1)  
State Office Building, 661 (1)

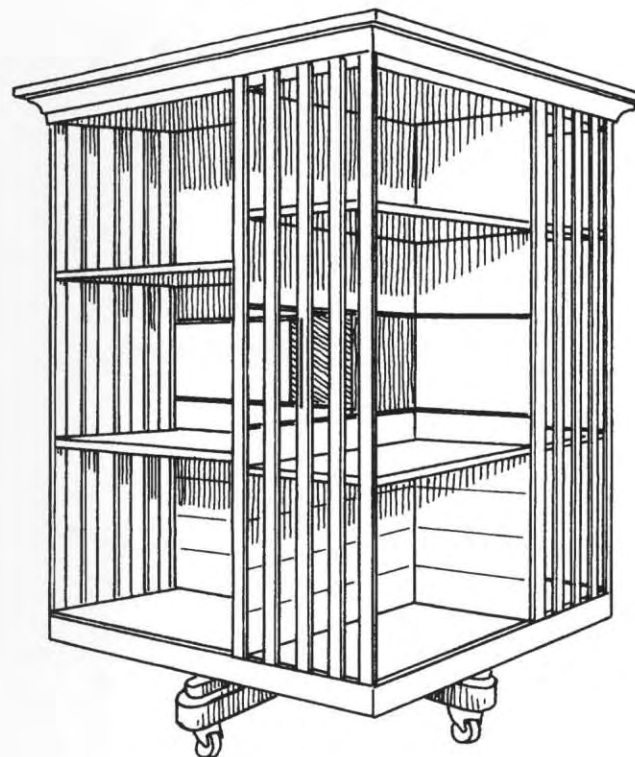

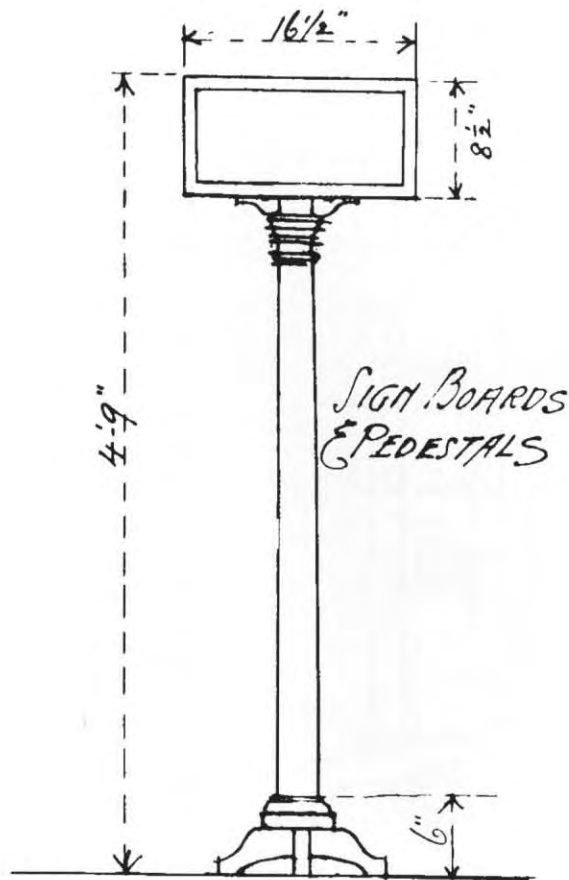

STYLE: R INSTRUCTIONAL SIGN

MAKER: Probably Stillwater Manufacturing Company,  
Stillwater, Minnesota

MEASUREMENT: 154h x 42.5w (sign)

DESCRIPTION: The R oak pedestal stand is topped by a blank announcement board 42.5 cm wide and 22-cm high. The board is attached to a tapered wood column with a metal rod running through the center. The column sits on four short curved legs with block feet.

HISTORY: Designed by Cass Gilbert for corridors throughout the Capitol

1905 ORDER: 35 (plus 13 reproductions 1988)

1989 TOTAL : 17

LOCATION: Capitol, B59 (1)  
Capitol, G17 (1)  
Capitol, 230 (1)  
Capitol, 2nd Floor, near 231 (1)  
Reproductions in various locations in Capitol  
Corridors (13)

Four styles of original furniture designed by Cass Gilbert have not been located. They include two styles shown here and two on the next page.

STYLE: RR ARMCHAIR

MAKER: Probably Marble & Stattuck Chair Company,  
Cleveland, Ohio

HISTORY: Designed by Cass Gilbert for the House Retiring  
Room

1905 ORDER: 8

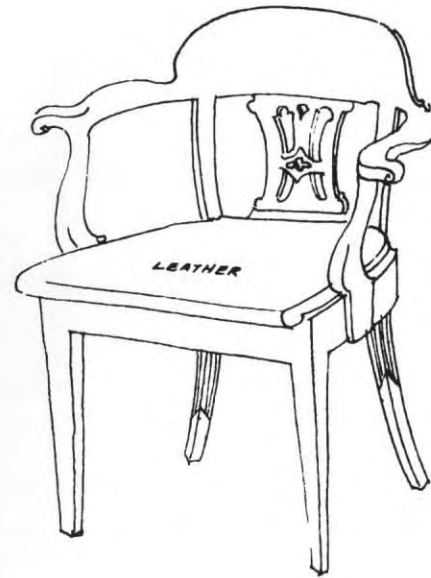

STYLE: KK WRITING DESK

MAKER: C. J. Cleaver, New York, New York

HISTORY: Designed by Cass Gilbert for the House Retiring  
Room and one "Ladies' Waiting Room"

1905 ORDER: 2

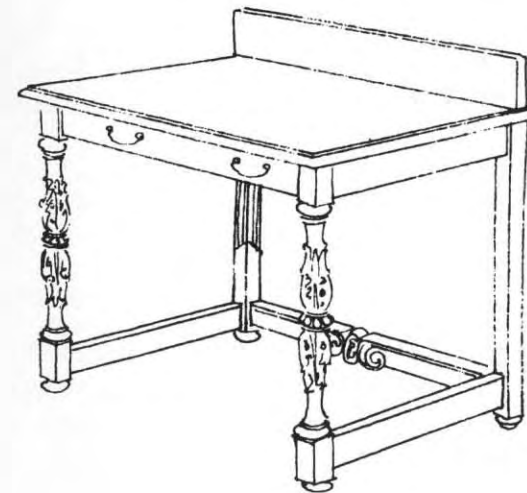

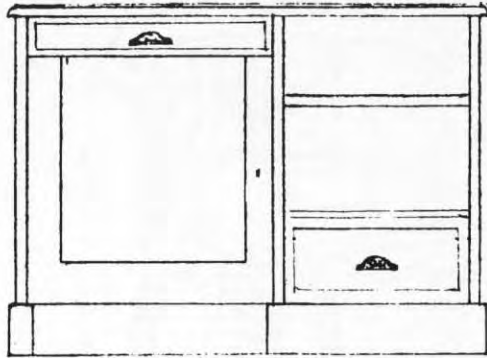

STYLE: AM MESSENGER TABLE

MAKER: Herter Brothers, New York, New York

HISTORY: Designed by Cass Gilbert for the Governor's Anteroom and Reception Room

1905 ORDER: 2 (plus 2 reproductions 1988, 1989)

1989 TOTAL: 2

LOCATION: Capitol, Governor's Anteroom (1)  
Capitol, Governor's Reception Room (1)

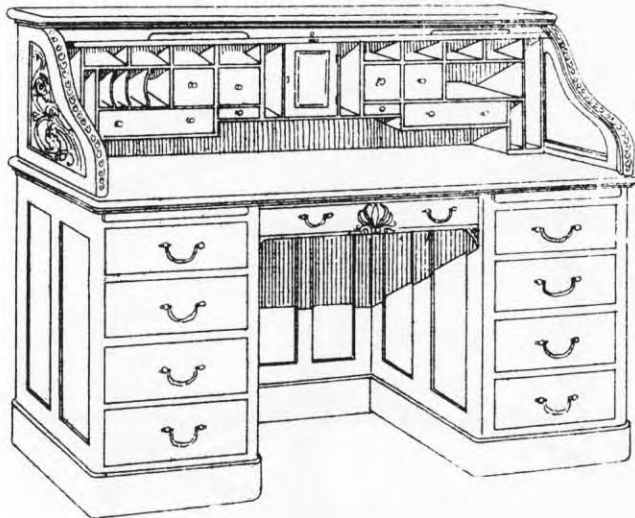

STYLE: SS ROLLTOP DESK

MAKER: Derby Desk Company, Boston, Massachusetts

HISTORY: Designed by Cass Gilbert for the Governor's Suite of Offices

1905 ORDER: 4



MINNESOTA HISTORICAL SOCIETY  
CAPITOL HISTORIC SITE PROGRAM